

CFP-100G-ER4

100Gbps CFP Transceiver, Single Mode, 40km Reach

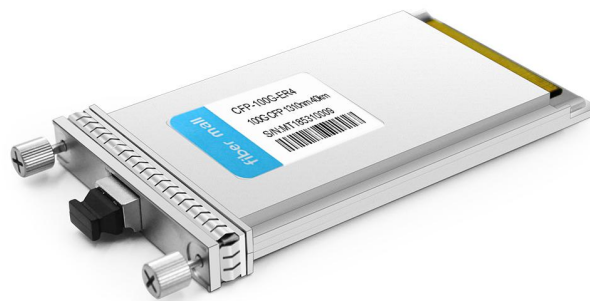

Product Features

- ❖ Supports multi-rate (100GBASE-100GE and OTU4); from 103.1Gb/s to 111.8Gb/s aggregate;
- ❖ Lane bit rate 25.78 Gb/s 100GE, 27.95 Gb/s OTU4;
- ❖ Up to 40km transmission on SMF;
- ❖ LAN WDM EML laser and PIN receiver with SOA;
- ❖ High speed I/O electrical interface (CAUI-10);
- ❖ MDIO interface with integrated Digital Diagnostic monitoring;
- ❖ CFP MSA package with duplex LC connector;

- ❖ Single +3.3V power supply;
- ❖ Maximum power consumption 16W;
- ❖ Operating case temperature: -5 to +70 ° C;
- ❖ Complies with IEEE802.3ba and ITU-T G.959
- ❖ Complies with EU Directive 2011/65/EU (RoHS 6/6)

Applications

- ❖ 100GBASE-ER4

Absolute Maximum Ratings

Parameter	Symbol	Min	Typical	Max	Unit	Notes
Storage Temperature	Ts	-40	-	+85	°C	
Supply Voltage	VCC	-0.5	-	+4.0	V	
Operating Relative Humidity	RH	-	-	+85	%	

Recommended Operating Conditions

Parameter	Symbol	Min	Typical	Max	Unit	Notes
Operating Case Temperature	TC	-5	-	+70	°C	
Power Supply Voltage	VCC	3.13	3.3	3.47	V	
Power Supply Current	ICC	-	-	5	A	
Maximum Power Dissipation	PD	-	-	16	W	
Aggregate Bit Rate	BR _{AVE}	-	103.125	-	Gb/s	
Lane Bit Rate	BR _{LANE}	-	25.78	-	Gb/s	
Transmission Distance	TD		-	40	km	Over SMF

Optical Characteristics

Parameter	Symbol	Min	Typical	Max	Unit	Notes
Transmitter						
Center Wavelength Lane 0	λ_0	1294.53	1295.56	1296.59	nm	
Center Wavelength Lane 1	λ_1	1299.02	1300.05	1301.09	nm	
Center Wavelength Lane 2	λ_2	1303.54	1304.58	1305.63	nm	
Center Wavelength Lane 3	λ_3	1308.09	1309.14	1310.19	nm	
Total Launch Power, 100GE	PALL	-	-	8.9	dBm	1
Average Launch Power per Lane, 100GE	PTX_LANE	-2.9	-	2.9	dBm	1
OMA per Lane, 100GE	OMA	0.1	-	4.5	dBm	1
OMA-TDP per Lane, 100GE	OMA_TDP	-	-	-	dBm	
Difference in launch power between lanes	PTX_DELTA_LANE	-	-	3.6	dB	
Total Launch Output Power, OTU4	PALL	-	-	8.9	dBm	1
Average Launch Power per Lane, OTU4	PTX_LANE	-2.9	-	2.9	dBm	1
Average Output Power (Laser Turn off)	P0UT-OFF	-	-	-30	dBm	
Side Mode Suppression Ratio	SMSR	30	-	-	dB	
Extinction Ratio, 100GE	ER	8	-	-	dB	
Transmitter and Dispersion Penalty	TDP	-	-	3.5	dB	2
Optical Return Loss Tolerance	ORLT	-	-	20	dB	
Optical Eye Mask, 100GE	Compliant with IEEE 802.3ba					2
Optical Eye Mask, OTU4	Compliant with ITU-T G.959.1					2
Receiver						
Center Wavelength Lane 0	λ_0	1294.53	1295.56	1296.59	nm	
Center Wavelength Lane 1	λ_1	1299.02	1300.05	1301.09	nm	
Center Wavelength Lane 2	λ_2	1303.54	1304.58	1305.63	nm	
Center Wavelength Lane 3	λ_3	1308.09	1309.14	1310.19	nm	
Average Rx Power per Lane, 100GE	PRX_LANE	-20.9		4.5	dBm	3
OMA Sensitivity per Lane, 100GE	POMA_LANE	-	-	-21.4	dBm	3
Average Rx Power per Lane, OTU4	PRX_AVE_LANE	-20.7		4.5	dBm	
Sensitivity per Lane, OTU4	PRX_AVE_LANE	-	-	-23.2	dBm	4

Receiver Overload	PIN-OL	4.5	-	-	dBm	
Reflectance	Ref	-	-	-26	dB	
LOS Assert per lane	LOSA	-40	-	-	dBm	
LOS De-assert	LOSD	-	-	-26	dBm	
LOS Hysteresis	LOSH	0.5	-	6	dB	

Notes:

1. The optical power is launched into SMF.
2. Measured with a PRBS $2^{31}-1$ test pattern @25.78125/27.952 Gb/s, Hit ratio $\leq 5E-5$.
3. Measured with a PRBS $2^{31}-1$ test pattern @25.78125 Gb/s, BER $\leq 1E-12$.
4. Measured with a PRBS $2^{31}-1$ test pattern @27.952 Gb/s, BER $\leq 1E-12$ (with FEC).

Electrical Characteristics

Low-Speed Signal: Compliant to CFP MSA Hardware Specification v 1.4

Parameter	Symbol	Min	Typical	Max	Unit	Notes
Transmitter (Module Input)						
Differential Data Input Amplitude	$V_{IN,P-P}$	85	-	850	mVpp	
Differential Termination Mismatch		-	-	5	%	
Tx_Disable	Normal Operation	V_{IL}	-0.3	-	0.8	V
	Laser Disable	V_{IH}	2.0	-	$V_{CC}+0.3$	V
Receiver (Module Output)						
Differential Data Output Amplitude	$V_{OUT,P-P}$	200	-	760	mVpp	
Differential Termination Mismatch (1MHZ)		-	-	5	%	
Output Rise/Fall Time, 20%~80%	T_R	12	-	-	ps	
Rx_LOS	Normal Operation	V_{OL}	-	-	0.2	V
	Lose Signal	V_{OH}	$V_{CC}-0.2$	-	-	V

Digital Diagnostics

Parameter	Range	Accuracy	Unit	Calibration
-----------	-------	----------	------	-------------

Temperature	-5 to 70	±3	°C	Internal
Voltage	0 to VCC	0.1	V	Internal
Tx Bias Current Per Lane	0 to 100	10%	mA	Internal
SOA Bias Current	0 to 130	10%	mA	Internal
Tx Output Power Per Lane	-3 to 3	±3	dBm	Internal
Rx Power (Each Lane)	-25 to 5	±3	dBm	Internal

Hardware Signal Pin Electrical Specification

Reference 3.3V LVCOMS output/input termination

Reference MDIO Interface Termination

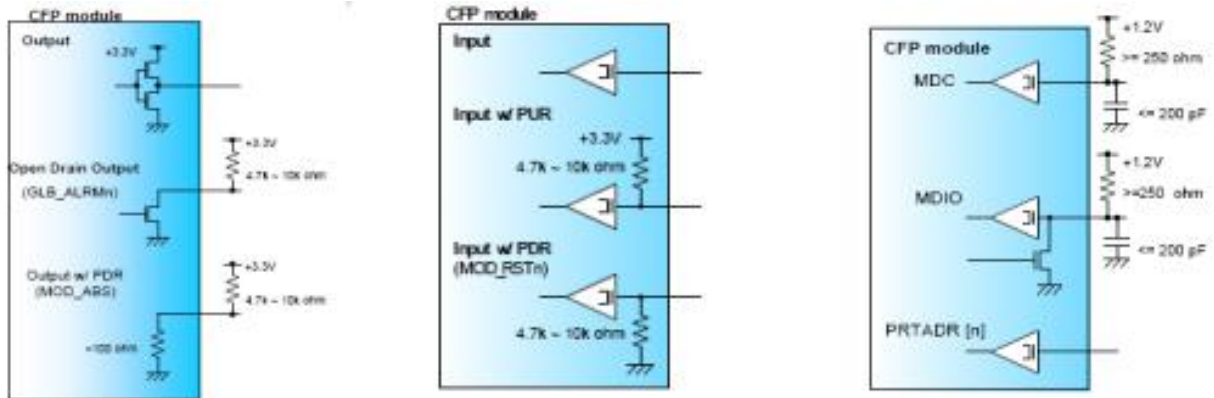

Note: The MSA recommends host termination resistor value of 560 Ohms, which provides the best balance of performance for both open-drain and active tri-state driver in the module.

Pin Definition

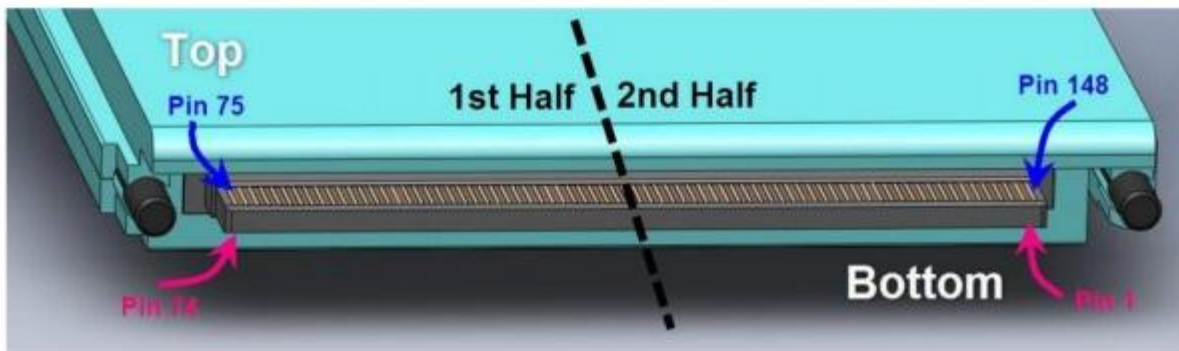

	Top Row (2nd Half)		Bottom Row (2nd Half)
148	GND	1	3.3V_GND
147	REFCLKn	2	3.3V_GND
146	REFCLKp	3	3.3V_GND
145	GND	4	3.3V_GND
144	N.C.	5	3.3V_GND
143	N.C.	6	3.3V
142	GND	7	3.3V
141	TX9n	8	3.3V
140	TX9p	9	3.3V
139	GND	10	3.3V
138	TX8n	11	3.3V
137	TX8p	12	3.3V
136	GND	13	3.3V
135	TX7n	14	3.3V
134	TX7p	15	3.3V
133	GND	16	3.3V_GND
132	TX6n	17	3.3V_GND
131	TX6p	18	3.3V_GND
130	GND	19	3.3V_GND
129	TX5n	20	3.3V_GND
128	TX5p	21	VND_IO_A
127	GND	22	VND_IO_B
126	TX4n	23	GND
125	TX4p	24	(TX_MCLKn)
124	GND	25	(TX_MCLKp)
123	TX3n	26	GND
122	TX3p	27	VND_IO_C
121	GND	28	VND_IO_D
120	TX2n	29	VND_IO_E
119	TX2p	30	PRG_CNTL1
118	GND	31	PRG_CNTL2
117	TX1n	32	PRG_CNTL3
116	TX1p	33	PRG_ALARM1
115	GND	34	PRG_ALARM2
114	TX0n	35	PRG_ALARM3
113	TX0p	36	TX_DIS
112	GND	37	MOD_LOPWR

	Top Row (1st Half)		Bottom Row (1st Half)
111	GND	38	MOD_ABS
110	N.C.	39	MOD_RSTn
109	N.C.	40	RX_LOS
108	GND	41	GLB_ALRMn
107	RX9n	42	PRTADR4
106	RX9p	43	PRTADR3
105	GND	44	PRTADR2
104	RX8n	45	PRTADR1
103	RX8p	46	PRTADR0
102	GND	47	MDIO
101	RX7n	48	MDC
100	RX7p	49	GND
99	GND	50	VND_IO_F
98	RX6n	51	VND_IO_G
97	RX6p	52	GND
96	GND	53	VND_IO_H
95	RX5n	54	VND_IO_J
94	RX5p	55	3.3V_GND
93	GND	56	3.3V_GND
92	RX4n	57	3.3V_GND
91	RX4p	58	3.3V_GND
90	GND	59	3.3V_GND
89	RX3n	60	3.3V
88	RX3p	61	3.3V
87	GND	62	3.3V
86	RX2n	63	3.3V
85	RX2p	64	3.3V
84	GND	65	3.3V
83	RX1n	66	3.3V
82	RX1p	67	3.3V
81	GND	68	3.3V
80	RX0n	69	3.3V
79	RX0p	70	3.3V_GND
78	GND	71	3.3V_GND
77	(RX_MCLKn)	72	3.3V_GND
76	(RX_MCLKp)	73	3.3V_GND
75	GND	74	3.3V_GND

Mechanical Dimension

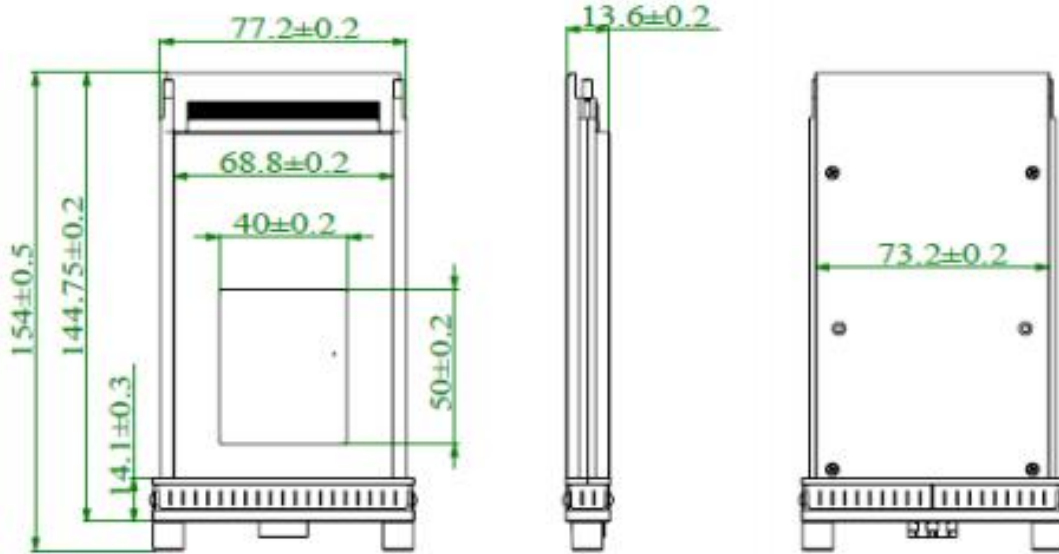

Ordering Information

Part Number	Product Description
CFP-100G-ER4	100Gbps CFP ER4, 1310nm, LC, 40km, -5°C~+70°C, with DDM