

# GPON-OLT-C++

GPON OLT 1490nm/1310nm Class C++ SFP Transceiver



## Product Features

- ❖ Single fiber bi-directional data links asymmetric TX 2488Mbps / RX1244Mbps application
- ❖ 1490nm continuous-mode DFB laser transmitter and 1310nm burst-mode APD-TIA receiver
- ❖ Small Form Factor Pluggable package with SC/UPC Connector
- ❖ Reset burst-mode receiver design support more than 15dB dynamic range
- ❖ 0 to 70° C operating temperature
- ❖ Single 3.3V power supply

- ❖ Digital diagnostic monitoring interface
- ❖ Digital burst RSSI function to monitor the input optical power level
- ❖ LVPECL compatible data input/output interface
- ❖ LVTTTL transmitter disable control
- ❖ LVTTTL transmitter laser fault alarm
- ❖ LVTTTL receiver Signal Detect
- ❖ Low EMI and excellent ESD protection
- ❖ Class I laser safety standard IEC-60825 compliant
- ❖ RoHS-6 compliance

## Applications

- ❖ Gigabit-capable Passive Optical Networks (GPON) Class C++ 20Km

## STANDARDS

- ❖ Complies with SFP Multi-Source Agreement (MSA) SFF-8074i
- ❖ Complies with SFF-8472 Rev 9.5
- ❖ Complies with ITU-T G.984.2 Amendment 2
- ❖ Complies with FCC 47 CFR Part 15, Class B
- ❖ Complies with FDA 21 CFR 1040.10 and 1040.11

## Absolute Maximum Ratings

Parameter	Symbol	Min	Max	Unit	Notes
Storage Ambient Temperature	T <sub>STG</sub>	-40	85	°C	
Operating Case Temperature	T <sub>c</sub>	0	70	°C	
Storage Humidity	OHs	5	95	%	
Power Supply Voltage	V <sub>cc</sub>	0	3.6	V	
Receiver Damaged Threshold		+5		dBm	

## Recommended Operating Conditions

Parameter	Symbol	Min	Typical	Max	Unit	Notes
Power Supply Voltage	$V_{cc}$	3.13	3.3	3.47	V	
Power Supply Current			350	500	mA	
Operating Case Temperature	$T_c$	0		70	°C	
Operating Humidity Range	OHo	5		85	%	
Nominal Data Rate			Tx 2488.32 Rx 1244.16		Mbit/s	

## Transmitter Optical Characteristics

Parameter	Symbol	Min	Typical	Max	Unit	Notes
Optical Center Wavelength	$\lambda_c$	1480		1500	nm	
Optical Spectrum Width (-20dB)	$\Delta\lambda$			1	nm	
Side Mode Suppression Ratio	SMSR	30			dB	
Average Launch Optical Power	AOP	+5.5		+10	dBm	BOL, Normal Temperature
		+4.5		+10	dBm	EOL, 0~70° C
Power-OFF Transmitter Optical Power				-39	dBm	Launched into SMF
Extinction Ratio	ER	8.2			dB	PRBS 2 <sup>23</sup> -1+72CID @2.488Gbit/s
Tolerance to Transmitter Incident Light		-15			dB	
Transmitter Reflectance				-10	dB	
Transmitter and Dispersion Penalty	TDP			1	dB	Transmit on 20km SMF
Optical Waveform Diagram	ITU-T G.984.2					See the figure below



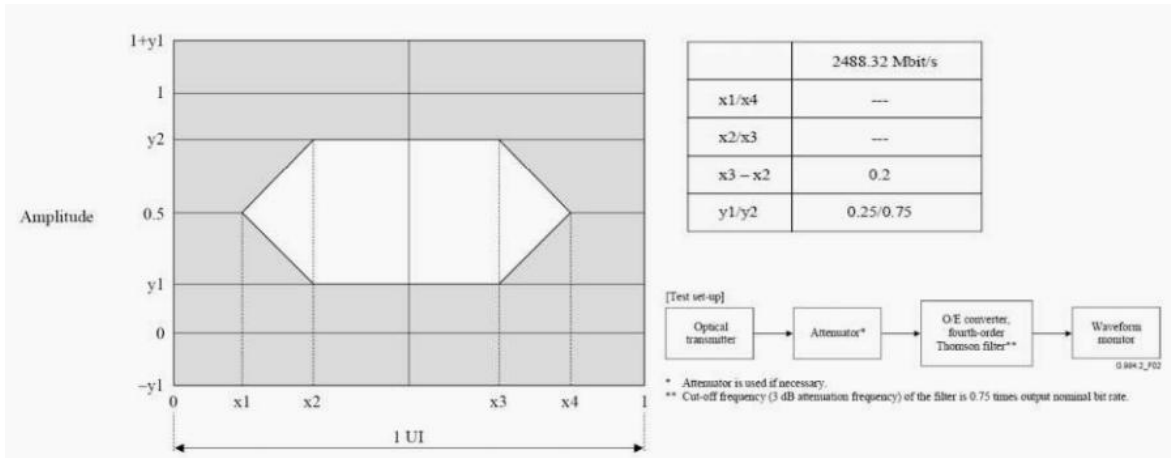

Transmitter Eye Mask Definitions and Test Procedure

## Transmitter Electrical Characteristics

Parameter	Symbol	Min	Typical	Max	Unit	Notes
Data Input Differential Swing		600		1600	mV	LVPECL input, AC coupled
Input Differential Impedance		90	100	110	$\Omega$	
Transmitter Disable Voltage - Low		0		0.8	V	
Transmitter Disable Voltage - High		2.0		V <sub>CC</sub>	V	
Transmitter Fault Alarm Voltage - Low		0		0.4	V	
Transmitter Fault Alarm Voltage - High		2.4		V <sub>CC</sub>	V	

## Receiver Optical Characteristics

Parameter	Symbol	Min	Typical	Max	Unit	Notes
Operating Wavelength		1290		1330	nm	
Sensitivity (BOL, Normal Temperature)	SEN			-31	dBm	PRBS 2 <sup>23</sup> . 1+72CID@1.24 4Gbps BER ≤ 1 × 10 <sup>-10</sup>
Sensitivity (EOL, 0~70° C)	SEN			-30		
Saturation Optical Power	SAT	-12			dBm	
Dynamic Range		15			dB	See the figure below
Loss Of Signal De-assert Level				-33	dBm	
Loss Of Signal Assert Level		-45			dBm	
Loss Of Signal Hysteresis		0.5		6	dB	
Receiver Reflectance				-12	dB	

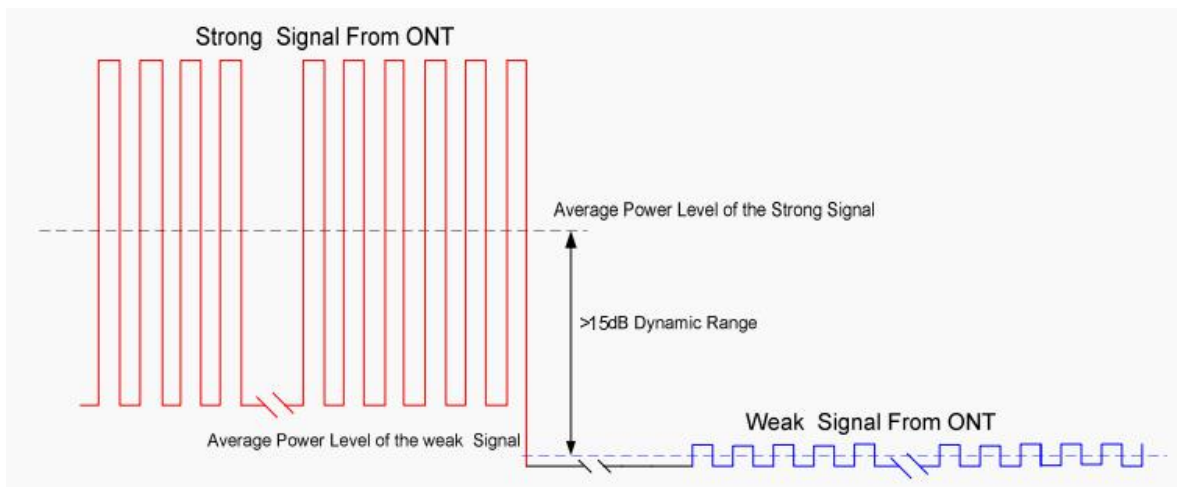

**Burst Mode Receiver Dynamic Range in GPON System**

## Receiver Electrical Characteristics

Parameter	Symbol	Min	Typical	Max	Unit	Notes
Data Output Voltage - Low (-Vcc)		-1.81		-1.62	V	
Data Output Voltage - High (-Vcc)		-1.02		-0.88	V	
Data Output Differential Swing		400		1600	mV	LVPECL output, DC coupled
Reset width	T <sub>RESET</sub>	16			bits	
Reset-Low		0		0.4	V	
Reset-High		2.4		Vcc	V	
Receiver Amplitude Recovery Time	T <sub>RECOVERY</sub>			32	bits	Refer to the Reset signal falling edge
Signal Detect Assert Time				50	ns	
Signal Detect De-assert Time				12.8	ns	Refer to the Reset signal rising edge
Signal Detect Voltage-Low		0		0.4	V	
Signal Detect Voltage-High		2.4		Vcc	V	
RSSI Trigger-Low		0		0.8	V	
RSSI Trigger-High		2.0		Vcc	V	
Optical Signal During Time	T <sub>ont</sub>	300			ns	
RSSI Trigger width	T <sub>w</sub>	300		T <sub>ont</sub> -T <sub>D</sub>	ns	
RSSI Trigger Delay	T <sub>D</sub>	0		3000	ns	
I <sup>2</sup> C Access Prohibited Time				500	μs	



## Timing Parameter Definitions in Burst More Sequence

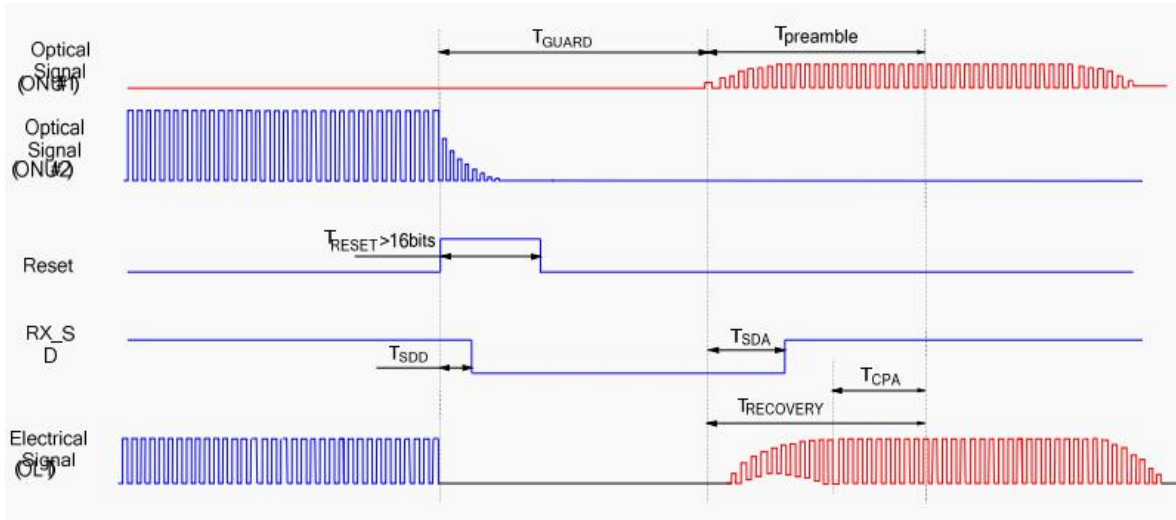

## RSSI Timing Sequence



## Pin Descriptions

Pin	Name	Description	Notes
1	V <sub>EE</sub> T	Transmitter Ground	
2	TX Fault	Transmitter Fault Indication	High: abnormal; Low: normal
3	TX Disable	Transmitter Disable	High: transmitter disable; Low: transmitter enable
4	MOD-DEF2	Module Definition 2	The data line of two wire serial interface
5	MOD-DEF1	Module Definition 1	The clock line of two wire serial interface
6	MOD-DEF0	Module Definition 0	Connected to Ground in the transceiver
7	Reset	Receiver Reset	High: reset the receiver
8	SD	Signal Detect	High: signal detected; Low: loss of signal
9	RSSI Trigger	RSSI Trigger for Transceiver A/D Conversion	High: enable RSSI A/D conversion
10	V <sub>EE</sub> R	Receiver Ground	
11	V <sub>EE</sub> R	Receiver Ground	
12	RD-	Inv. Receiver Data Out	LVPECL logic output, DC coupled
13	RD+	Receiver Data Out	LVPECL logic output, DC coupled
14	V <sub>EE</sub> R	Receiver Ground	
15	V <sub>CC</sub> R	Receiver Power	
16	V <sub>CC</sub> T	Transmitter Power	
17	V <sub>EE</sub> T	Transmitter Ground	
18	TD+	Transmit Data In	LVPECL logic input, AC coupled
19	TD-	Inv. Transmit Data In	LVPECL logic input, AC coupled
20	V <sub>EE</sub> T	Transmitter Ground	



### SFP Recommended Host Board Power Supply Filtering Network

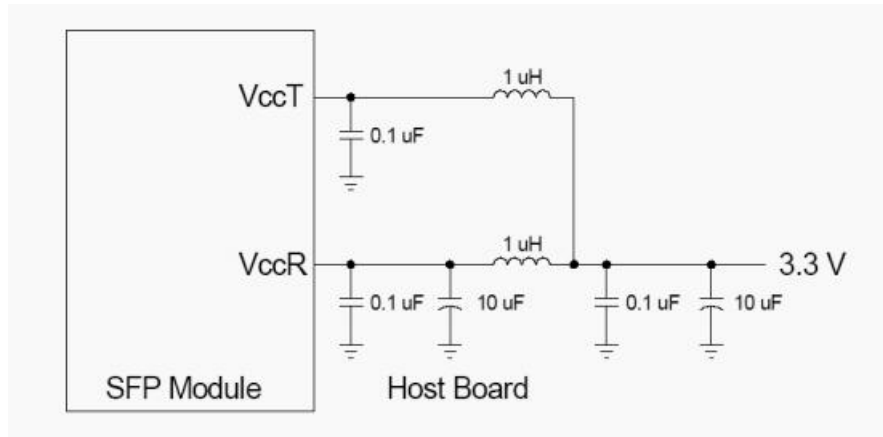

### SFP Pin (Golden Finger) Drawing

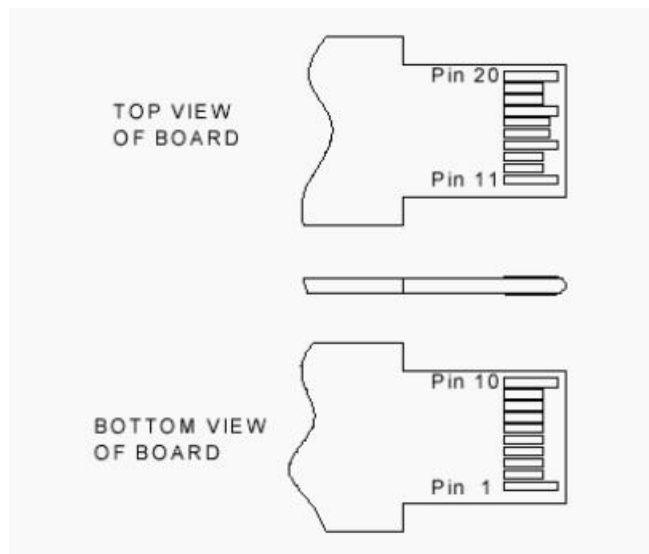

## Typical Interface Circuit

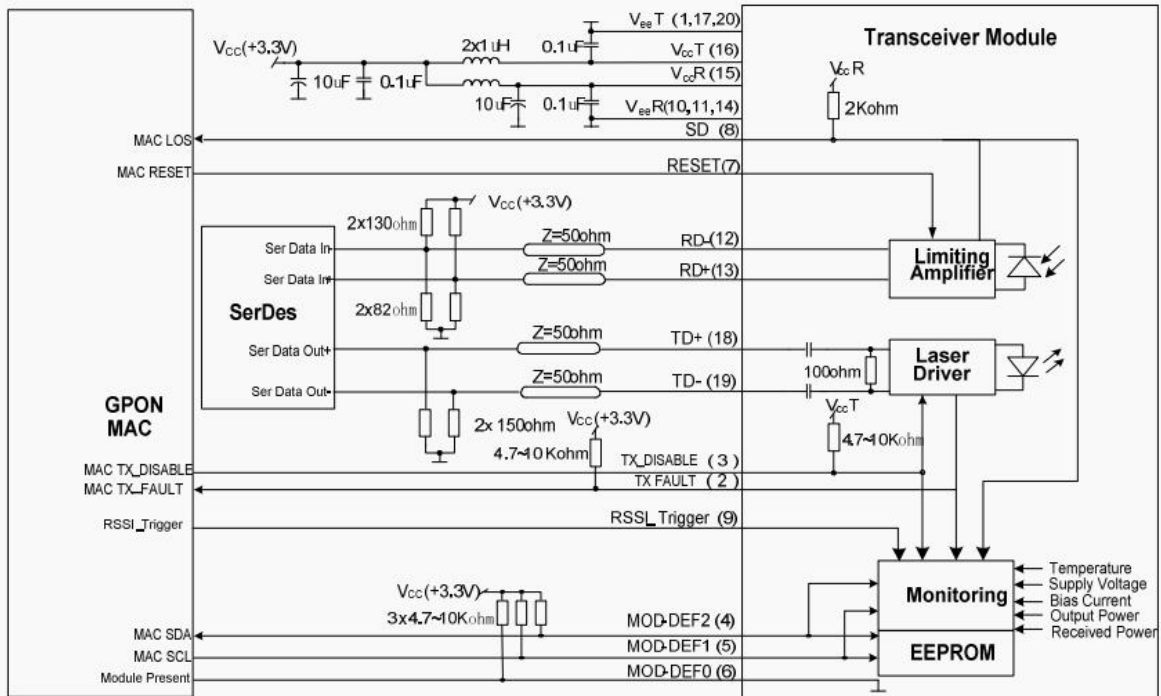

## Digital Diagnostic Monitoring

Parameter	Range	Accuracy	Calibration	Note
Temperature	0 to +70 °C	±3°C	Internal	1LSB = 1/256° C
Voltage	0 to 6.55 V	±3%	Internal	1LSB = 0.1mV
Bias Current	0 to 100 mA	±10%	Internal	1LSB = 2uA
TX Power	0 to 8 dBm	±2dB	Internal	1LSB = 0.1uW
RX Power Monitor	-30 to -10 dBm	±2dB@25° C ±3dB@0~70° C	External	1LSB = 0.1uW

## Mechanical Specifications

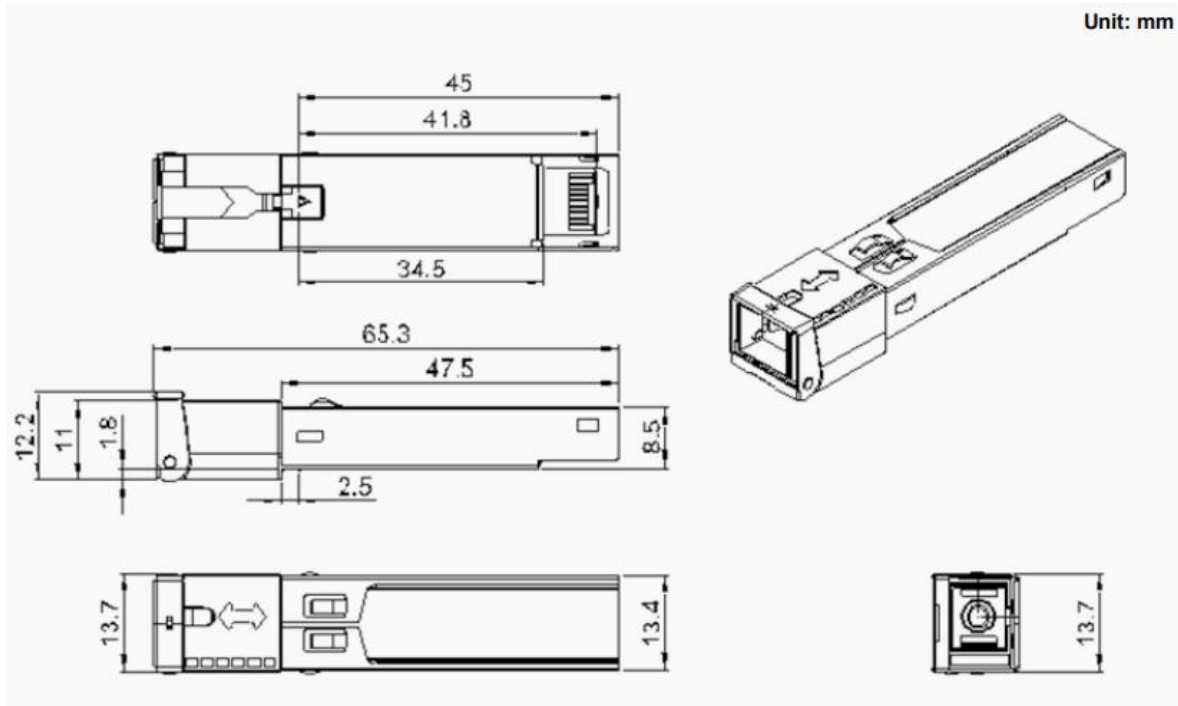

## Ordering Information

Part Number	Product Description
GPON-OLT-C++	SFP, 2.5G/1.25G, 1490nm/1310nm, SC/UPC, GPON OLT Class C++, 0 ~ +70°C, with DDM