

QSFP28-100G-LR1

100Gbps QSFP28 Single Lambda LR Transceiver

Single Mode, 10km Reach



Product Features

- ❖ QSFP28 MSA compliant
- ❖ Supports 53.125Gbaud
- ❖ 100G Lambda MSA 100G-LR Specification compliant
- ❖ Up to 10km transmission on single mode fiber (SMF) with FEC
- ❖ Operating case temperature: 0 to 70oC

- ❖ 4x25G electrical interface (OIF CEI-28G- VSR)
- ❖ Maximum power consumption 4.5W
- ❖ LC duplex connector
- ❖ RoHS compliant

Applications

- ❖ Data Center Interconnect
- ❖ 100G Ethernet
- ❖ Enterprise networking

General Description

This product is a transceiver module designed for 10km optical communication applications. The module incorporates one channel optical signal, on 1310nm center wavelength, operating at 50Gbaud data rate. The transmitter path incorporates an EML Driver and a cooled EML together. On the receiver path, the input optical signal is coupled to a Pin photodiode detector. A DSP based gearbox is used to convert 4x25Gbps NRZ signals to 1x50Gbaud PAM4 signal. Also a 4-channel retimer and FEC block are integrated in this DSP. The electrical interface is compliant with IEEE 802.3cd and QSFP28 MSA in the transmitting and receiving directions, and optical interface is compliant to IEEE 802.3cd and 100G Lambda MSA with Duplex LC connector. The module has a maximum power consumption of 4.5W.

The product is designed with form factor, optical/electrical connection and digital diagnostic interface according to the QSFP28 Multi-Source Agreement (MSA). It has been designed to meet the harshest external operating conditions including temperature, humidity and EMI interference.

Functional Description

This product converts the 4-channel of 100Gbps aggregated NRZ electrical input data into one channel of 50Gbaud PAM4 optical signal (light) on 1310nm center wavelength through a DSP based gearbox, by a driven cooled Electro-absorption Modulated DFB Laser (EML). The light propagates out of the transmitter into an SMF fiber. The receiver module accepts the 50Gbaud PAM4 optical signal input, and converts it into a 50Gbaud PAM4 electrical signal via a linear amplifier. And then convert the 50Gbaud PAM4 signal into 4 channels of 25Gbps NRZ signals. Figure “Transceiver Block Diagram” shows the functional block diagram of this product.

A single +3.3V power supply is required to power up this product. Both power supply pins VccTx and VccRx are internally connected and should be applied concurrently. As per MSA specifications the module offers seven low speed hardware control pins (including the 2-wire serial interface): ModSelL, SCL, SDA, ResetL, LPMode, ModPrsL and IntL.

Module Select (ModSelL) is an input pin. When held low by the host, this product responds to 2- wire serial communication commands. The ModSelL allows the use of this product on a single 2- wire interface bus – individual ModSelL lines must be used.

Serial Clock (SCL) and Serial Data (SDA) are required for the 2-wire serial bus communication interface and enable the host to access the memory map.

The ResetL pin enables a complete reset, returning the settings to their default state, when a low level on the ResetL pin is held for longer than the minimum pulse length. During the execution of a reset the host shall disregard all status bits until it indicates a completion of the reset interrupt. The product indicates this by posting an IntL (Interrupt) signal with the Data_Not_Ready bit negated in the memory map. Note that on power up (including hot insertion) the module should post this completion of reset interrupt without requiring a reset.

Low Power Mode (LPMode) pin is used to set the maximum power consumption for the product in order to protect hosts that are not capable of cooling higher power modules, should such modules be accidentally inserted.

Module Present (ModPrsL) is a signal local to the host board which, in the absence of a product, is normally pulled up to the host Vcc. When the product is inserted into the connector, it completes the path to ground through a resistor on the host board and asserts the signal. ModPrsL then indicates its present by setting ModPrsL to a “Low” state.

Interrupt (IntL) is an output pin. “Low” indicates a possible operational fault or a status critical to the host system. The host identifies the source of the interrupt using the 2-wire serial interface. The IntL pin is an open collector output and must be pulled to the Host Vcc voltage on the Host board.

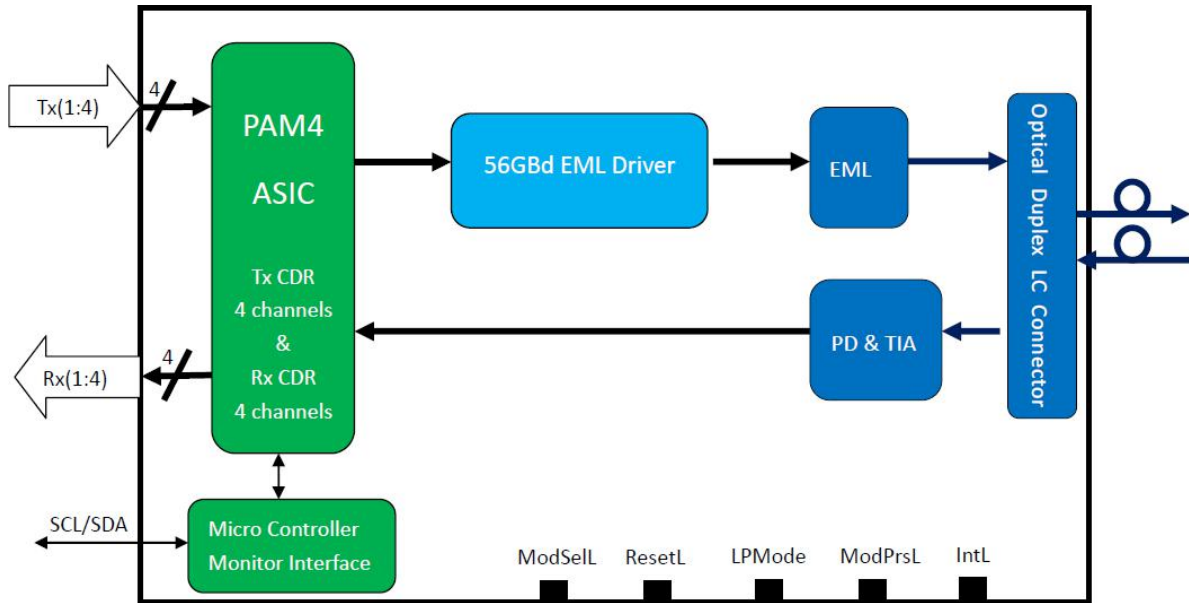

Transceiver functional diagram

Absolute Maximum Ratings

It has to be noted that the operation in excess of any individual absolute maximum ratings might cause permanent damage to this module.

| Parameter | Symbol | Min | Max | Units | Notes |
|--------------------------------------|-----------------|------|-----|-------|-------|
| Storage Temperature | T _s | -40 | 85 | degC | |
| Operating Case Temperature | T _{OP} | 0 | 70 | degC | |
| Power Supply Voltage | V _{CC} | -0.5 | 3.6 | V | |
| Relative Humidity (non-condensation) | RH | 0 | 85 | % | |
| Damage Threshold, each Lane | TH _d | 5.5 | | dBm | |

Recommended Operating Conditions

| Parameter | Symbol | Min | Typical | Max | Units | Notes |
|---------------------------------------|-----------------|-------|----------|----------------------|-------|-------|
| Operating Case Temperature | T _{OP} | 0 | | 70 | degC | |
| Power Supply Voltage | V _{CC} | 3.135 | 3.3 | 3.465 | V | |
| Electrical Data Rate, each Lane (NRZ) | | | 25.78125 | | Gb/s | |
| Optical Data Rate (PAM4) | | | 53.125 | | GBd | |
| Data Rate Accuracy | | -100 | | 100 | ppm | |
| Pre-FEC Bit Error Ratio | | | | 2.4x10 ⁻⁴ | | |
| Post-FEC Bit Error Ratio | | | | 1x10 ⁻¹² | | 1 |
| Control Input Voltage High | | 2 | | V _{CC} | V | |
| Control Input Voltage Low | | 0 | | 0.8 | V | |
| Link Distance with G.652 | D | 0.002 | | 10 | km | 2 |

Notes:

1. FEC feature is embedded in the module.
2. FEC required to be turned on to support maximum transaction distance.

Optical Characteristics

| Parameter | Symbol | Min | Typical | Max | Units | Notes |
|---|------------------|--------|---------|--------|-------|--------------|
| Transmitter | | | | | | |
| Center Wavelength | λ _t | 1304.5 | | 1317.5 | nm | |
| Side Mode Suppression Ratio | SMSR | 30 | | | dB | |
| Average Launch Power | P _{AVG} | -1.4 | | 4.5 | dBm | 1 |
| Outer Optical Modulation Amplitude (OMA _{outer}) | P _{OMA} | 0.7 | | 4.7 | dBm | 2 |
| Launch Power in OMA _{outer} minus Transmitter and Dispersion Eye Closure (TDECQ) | | -0.7 | | | dBm | for ER≥4.5dB |
| Launch Power in OMA _{outer} minus Transmitter and Dispersion Eye Closure (TDECQ) | | -0.6 | | | dBm | for ER<4.5dB |

| | | | | | | |
|--|------------------|--------|-----|--------|-------|-------------------------------|
| Transmitter and Dispersion Eye Closure for PAM4 (TDECQ) | TDECQ | | | 3.4 | dB | |
| Extinction Ratio | ER | 3.5 | | | dB | |
| RIN15.6OMA | RIN | | | -136 | dB/Hz | |
| Optical Return Loss Tolerance | TOL | | | 15.6 | dB | |
| Transmitter Reflectance | R _T | | | -26 | dB | |
| Average Launch Power OFF Transmitter | P _{off} | | | -15 | dBm | |
| Receiver | | | | | | |
| Center Wavelength | λ _r | 1304.5 | | 1317.5 | nm | |
| Damage Threshold | THd | 5.5 | | | dBm | 3 |
| Average Receive Power | | -7.7 | | 4.5 | dBm | |
| Receive Power (OMA _{outer}) | | | | -6.1 | dBm | for BER= 2.4x10 ⁻⁴ |
| Receiver Sensitivity (OMA _{outer}) | SEN | | | -4.5 | dBm | for BER= 2.4x10 ⁻⁴ |
| Stressed Receiver Sensitivity (OMA _{outer}) | SRS | | | -4.1 | dBm | |
| Receiver Reflectance | R _R | | | -26 | dB | |
| LOS Assert | LOSA | -30 | | | dBm | |
| LOS Deassert | LOSD | | | -15 | dBm | |
| LOS Hysteresis | LOSH | 0.5 | | | dB | |
| Conditions of Stress Receiver Sensitivity Test (Note 4) | | | | | | |
| Stressed Eye Closure for PAM4 (SECQ) | | | 3.4 | | dB | |

Notes:

1. Average launch power, each lane min is informative and not the principal indicator of signal strength. A transmitter with launch power below this value cannot be compliant; however, a value above this does not ensure compliance
2. Even if the TDECQ < 1.4dB for an extinction ratio of ≥ 4.5dB or TDECQ < 1.3dB for an extinction ratio of < 4.5dB, the OMA_{outer} (min) must exceed the minimum value specified here.
3. The receiver shall be able to tolerate, without damage, continuous exposure to a modulated optical input signal having this power level on one lane. The receiver does not have to operate correctly at this input power.
4. Stressed eye closure definition is test condition for measuring stressed receiver sensitivity. It is not a characteristic of the receiver.

Electrical Characteristics

The following electrical characteristics are defined over the Recommended Operating Environment unless otherwise specified.

| Parameter | Test Point | Min | Typical | Max | Units | Notes |
|--|-----------------|--------------------------------------|---------|---------------------------------|-------|---------|
| Power Consumption | | | | 4.5 | W | |
| Supply Current | I _{cc} | | | 1.36 | A | |
| Transmitter (each Lane) | | | | | | |
| Overload Differential Voltage pk-pk | TP1a | 900 | | | mV | |
| Common Mode Voltage (V _{cm}) | TP1 | -350 | | 2850 | mV | 1 |
| Differential Termination Resistance Mismatch | TP1 | | | 10 | % | At 1MHz |
| Differential Return Loss (SDD11) | TP1 | | | See CEI- 28G-VSR Equation 13-19 | dB | |
| Common Mode to Differential conversion and Differential to Common Mode conversion (SDC11, SCD11) | TP1 | | | See CEI- 28G-VSR Equation 13-20 | dB | |
| Stressed Input Test | TP1a | See CEI- 28G-VSR Section 13.3.11.2.1 | | | | |
| Receiver (each Lane) | | | | | | |
| Differential Voltage, pk-pk | TP4 | | | 900 | mV | |
| Common Mode Voltage (V _{cm}) | TP4 | -350 | | 2850 | mV | 1 |
| Common Mode Noise, RMS | TP4 | | | 17.5 | mV | |
| Differential Termination Resistance Mismatch | TP4 | | | 10 | % | At 1MHz |
| Differential Return Loss (SDD22) | TP4 | | | See CEI- 28G-VSR Equation 13-19 | dB | |
| Common Mode to Differential conversion and Differential to Common Mode conversion (SDC22, SCD22) | TP4 | | | See CEI- 28G-VSR Equation 13-21 | dB | |
| Common Mode Return Loss (SCC22) | TP4 | | | -2 | dB | 2 |
| Transition Time, 20 to 80% | TP4 | 9.5 | | | ps | |
| Vertical Eye Closure (VEC) | TP4 | | | 5.5 | dB | |

| | | | | | | |
|--|-----|------|--|--|----|--|
| Eye Width at 10-15 probability (EW15) | TP4 | 0.57 | | | UI | |
| Eye Height at 10-15 probability (EH15) | TP4 | 228 | | | mV | |

Notes:

1. Vcm is generated by the host. Specification includes effects of ground offset voltage.
2. From 250MHz to 30GHz.

Pin Assignment and Description

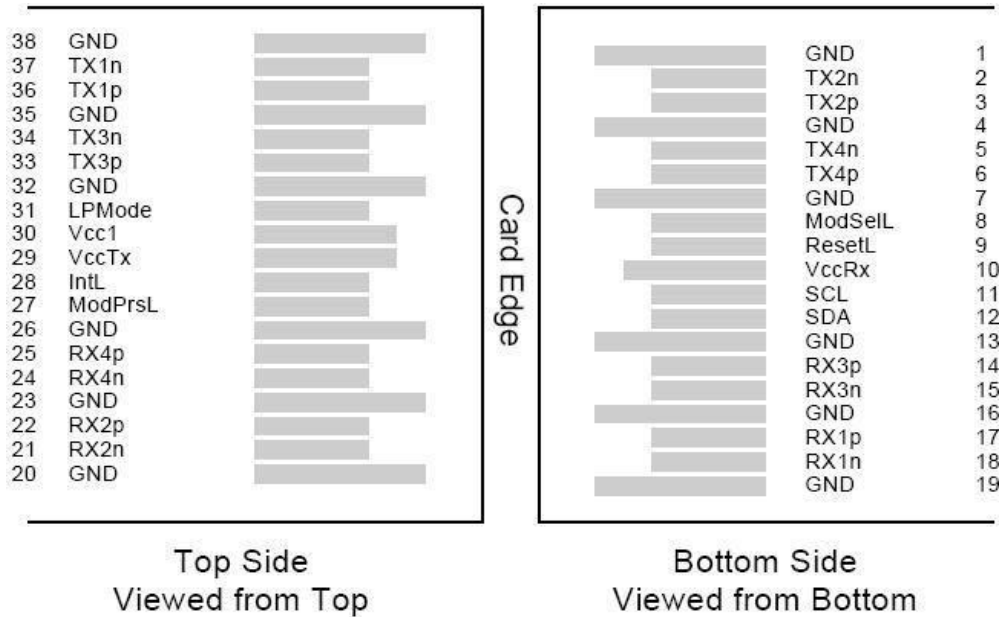

MSA Compliant Connector

Pin Definition

| PIN | Logic | Symbol | Name/Description | Notes |
|-----|-------------|---------|--------------------------------------|-------|
| 1 | | GND | Ground | 1 |
| 2 | CML-I | Tx2n | Transmitter Inverted Data Input | |
| 3 | CML-I | Tx2p | Transmitter Non-Inverted Data output | |
| 4 | | GND | Ground | 1 |
| 5 | CML-I | Tx4n | Transmitter Inverted Data Input | |
| 6 | CML-I | Tx4p | Transmitter Non-Inverted Data output | |
| 7 | | GND | Ground | 1 |
| 8 | LVTLL-I | ModSelL | Module Select | |
| 9 | LVTLL-I | ResetL | Module Reset | |
| 10 | | VccRx | +3.3V Power Supply Receiver | 2 |
| 11 | LVC MOS-I/O | SCL | 2-Wire Serial Interface Clock | |
| 12 | LVC MOS-I/O | SDA | 2-Wire Serial Interface Data | |
| 13 | | GND | Ground | |
| 14 | CML-O | Rx3p | Receiver Non-Inverted Data Output | |
| 15 | CML-O | Rx3n | Receiver Inverted Data Output | |
| 16 | | GND | Ground | 1 |
| 17 | CML-O | Rx1p | Receiver Non-Inverted Data Output | |
| 18 | CML-O | Rx1n | Receiver Inverted Data Output | |
| 19 | | GND | Ground | 1 |
| 20 | | GND | Ground | 1 |
| 21 | CML-O | Rx2n | Receiver Inverted Data Output | |
| 22 | CML-O | Rx2p | Receiver Non-Inverted Data Output | |
| 23 | | GND | Ground | 1 |
| 24 | CML-O | Rx4n | Receiver Inverted Data Output | 1 |
| 25 | CML-O | Rx4p | Receiver Non-Inverted Data Output | |
| 26 | | GND | Ground | 1 |

| | | | | |
|----|---------|---------|-------------------------------------|---|
| 27 | LVTTL-O | ModPrsL | Module Present | |
| 28 | LVTTL-O | IntL | Interrupt | |
| 29 | | VccTx | +3.3 V Power Supply transmitter | 2 |
| 30 | | Vcc1 | +3.3 V Power Supply | 2 |
| 31 | LVTTL-I | LPMode | Low Power Mode | |
| 32 | | GND | Ground | 1 |
| 33 | CML-I | Tx3p | Transmitter Non-Inverted Data Input | |
| 34 | CML-I | Tx3n | Transmitter Inverted Data Output | |
| 35 | | GND | Ground | 1 |
| 36 | CML-I | Tx1p | Transmitter Non-Inverted Data Input | |
| 37 | CML-I | Tx1n | Transmitter Inverted Data Output | |
| 38 | | GND | Ground | 1 |

Notes:

1. GND is the symbol for signal and supply (power) common for QSFP28 modules. All are common within the QSFP28 module and all module voltages are referenced to this potential unless otherwise noted. Connect these directly to the host board signal common ground plane.
2. VccRx, Vcc1 and VccTx are the receiving and transmission power suppliers and shall be applied concurrently. Recommended host board power supply filtering is shown in Figure below. Vcc Rx, Vcc1 and Vcc Tx may be internally connected within the QSFP28 transceiver module in any combination. The connector pins are each rated for a maximum current of 1000mA.

Recommended Power Supply Filter

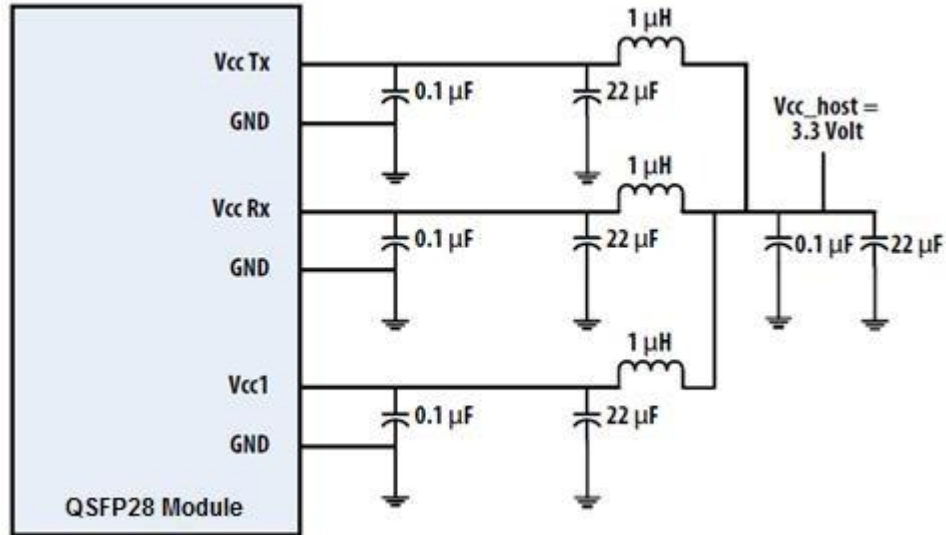

Digital Diagnostic Functions

The following digital diagnostic characteristics are defined over the normal operating conditions unless otherwise specified.

| Parameter | Symbol | Min | Max | Units | Notes |
|---|--------------|------|-----|-------|----------------------------------|
| Temperature monitor absolute error | DMI_Temp | -3 | 3 | degC | Over operating temperature range |
| Supply voltage monitor absolute error | DMI_VCC | -0.1 | 0.1 | V | Over full operating range |
| Channel RX power monitor absolute error | DMI_RX_Ch | -2 | 2 | dB | 1 |
| Channel Bias current monitor | DMI_ibias_Ch | -10% | 10% | mA | |
| Channel TX power monitor absolute error | DMI_TX_Ch | -2 | 2 | dB | 1 |

Notes:

1. Due to measurement accuracy of different single mode fibers, there could be an additional +/-1 dB fluctuation, or a +/- 3 dB total accuracy.

Mechanical Dimensions

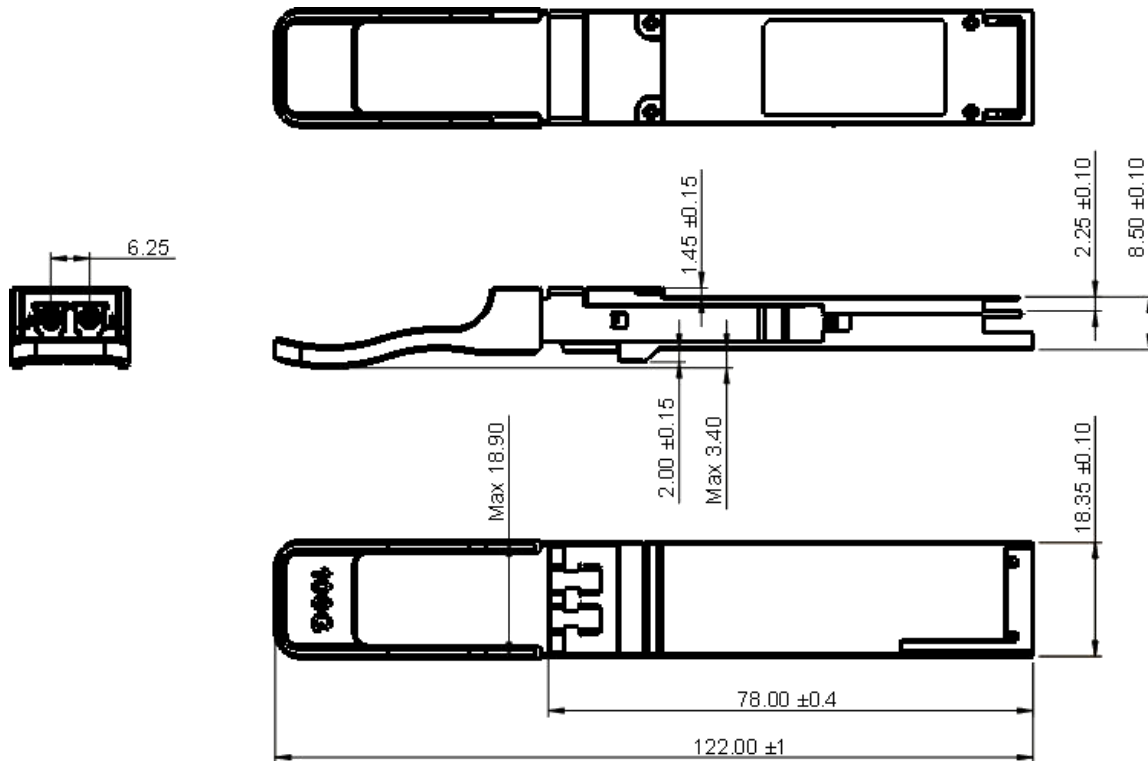

ESD

This transceiver is specified as ESD threshold 1kV for high speed data pins and 2kV for all other electrical input pins, tested per MIL-STD-883, Method 3015.4 /JESD22-A114-A (HBM). However, normal ESD precautions are still required during the handling of this module. This transceiver is shipped in ESD protective packaging. It should be removed from the packaging and handled only in an ESD protected environment.

Laser Safety

This is a Class 1 Laser Product according to EN 60825-1:2014. This product complies with 21 CFR 1040.10 and 1040.11 except for deviations pursuant to Laser Notice No. 50, dated (June 24, 2007).

Caution: Use of controls or adjustments or performance of procedures other than those specified herein may result in hazardous radiation exposure.

Ordering Information

| Part Number | Product Description |
|--------------------|--|
| QSFP28-100G-LR1 | 100Gbps QSFP28 LR Single Lambda, 1310nm, LC Connector, 10km, 0°C~+70°C, with DDM |