

QSFP-40G-ZR4

40Gbps QSFP+ ZR4 Transceiver, Single Mode, 80km Reach



Product Features

- ❖ 4 lanes MUX/DEMUX design
- ❖ Integrated LAN WDM TOSA / ROSA
- ❖ Up to 11.2Gbps per channel bandwidth
- ❖ Aggregate bandwidth of > 40Gbps
- ❖ Duplex LC connector
- ❖ Compliant with 40G Ethernet IEEE802.3ba and 40GBASE-ZR4
- ❖ QSFP MSA compliant
- ❖ APD photo-detector

- ❖ Up to 80 km transmission
- ❖ Compliant with QDR/DDR Infiniband data rates
- ❖ Single +3.3V power supply operating
- ❖ Built-in digital diagnostic functions
- ❖ Temperature range 0° C to 70° C
- ❖ RoHS Compliant Part

Applications

- ❖ Data Centers Switches and Routers
- ❖ Switches and Routers
- ❖ Rack to Rack
- ❖ Metro Networks
- ❖ 40GBASE-ZR4

Description

This QSFP-40G-ZR4 is a transceiver module designed for 80km optical communication applications. The design is compliant to 40GBASE-ER4 of the IEEE P802.3ba standard. The module converts 4 inputs channels of 10Gb/s electrical data to 4 CWDM optical signals, and multiplexes them into a single channel for 40Gb/s optical transmission. Reversely, on the receiver side, the module optically de-multiplexes a 40Gb/s input into 4 CWDM channels signals, and converts them to 4 channel output electrical data.

The central wavelengths of the 4 LANWDM channels are 1296 nm, 1300 nm, 1305 nm and 1309 nm as members of the LAN WDM wavelength grid defined in ITU-T G694.2. It contains a duplex LC connector for the optical interface and a 38-pin connector for the electrical interface. To minimize the optical dispersion in the long-haul system, single-mode fiber (SMF) has to be applied in this module.

The product is designed with form factor, optical/electrical connection and digital diagnostic interface according to the QSFP Multi-Source Agreement (MSA). It has been designed to meet the harshest external operating conditions including temperature, humidity and EMI interference.

The module operates from a single +3.3V power supply and LVCMOS/LVTTL global control signals such as Module Present, Reset, Interrupt and Low Power Mode are available with the modules. A 2-wire serial interface is available to send and receive more complex control signals and to obtain digital diagnostic information. Individual channels can be addressed and unused channels can be shut down for maximum design flexibility.

The QSFP-40G-ZR4 is designed with form factor, optical/electrical connection and digital diagnostic interface according to the QSFP Multi-Source Agreement (MSA). It has been

designed to meet the harshest external operating conditions including temperature, humidity and EMI interference. The module offers very high functionality and feature integration, accessible via a two-wire serial interface.

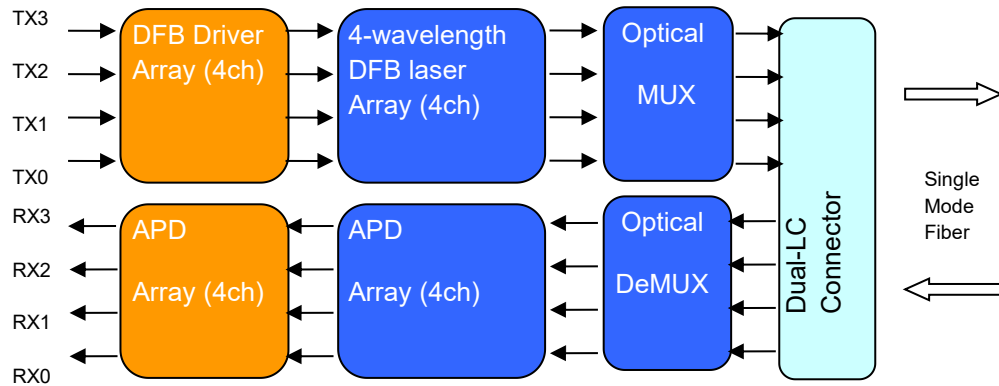

40Gb/s QSFP ZR4 Transceiver Block Diagram

Absolute Maximum Ratings

Parameter	Symbol	Min	Typical	Max	Unit
Storage Temperature	T_s	-40		+85	°C
Supply Voltage	$V_{ccT, R}$	-0.5		4	V
Relative Humidity	RH	0		85	%

Recommended Operating Environment

Parameter	Symbol	Min	Typical	Max	Unit
Case Operating Temperature	T_c	0		+70	°C
Supply Voltage	$V_{ccT, R}$	+3.13	3.3	+3.47	V
Supply Current	I_{cc}			1000	mA
Power Dissipation	PD			3.5	W

Electrical Characteristics (T_{OP} = 0 to 70 °C, VCC = 3.13 to 3.47 Volts)

Parameter	Symbol	Min	Typical	Max	Unit	Note
Data Rate per Channel		-	10.3125	11.2	Gbps	
Power Consumption		-	2.5	5	W	
Supply Current	I _{cc}		0.75	1.3	A	
Control I/O Voltage-High	V _{IH}	2.0		V _{cc}	V	
Control I/O Voltage-Low	V _{IL}	0		0.7	V	
Inter-Channel Skew	TSK			150	Ps	
RESETL Duration			10		Us	
RESETL De-assert time				100	ms	
Power On Time				100	ms	
Transmitter						
Single Ended Output Voltage Tolerance		0.3		4	V	1
Common mode Voltage Tolerance		15			mV	
Transmit Input Diff Voltage	V _I	150		1200	mV	
Transmit Input Diff Impedance	Z _{IN}	85	100	115		
Data Dependent Input Jitter	DDJ		0.3		UI	
Receiver						
Single Ended Output Voltage Tolerance		0.3		4	V	
Rx Output Diff Voltage	V _o	370	600	950	mV	
Rx Output Rise and Fall Voltage	Tr/Tf			35	ps	1
Total Jitter	TJ		0.3		UI	

Notes:

1. 20%~80%

Optical Parameters (TOP = 0 to 70 °C, VCC = 3.0 to 3.6 Volts)

Parameter	Symbol	Min	Typical	Max	Unit	Notes
Transmitter						
Wavelength Assignment	L0	1294.53	1295.56	1296.59	nm	
	L1	1299.02	1300.05	1301.09	nm	
	L2	1303.54	1304.58	1305.63	nm	
	L3	1308.09	1309.14	1310.19	nm	
Side-mode Suppression Ratio	SMSR	30	-	-	dB	
Total Average Launch Power	PT		-	10.5	dBm	
Average Launch Power, each Lane		+4	-	7	dBm	
Transmit OMA per Lane	TxOMA	0.3		5.0	dBm	
Difference in launch power between any two lanes (OMA)				4.7	dBm	
Transmitter Dispersion Penalty each Lane	TDP			2.6	dB	
Extinction Ratio	ER	5.5	6.5		dB	
Transmitter Eye Mask Definition {X1, X2, X3, Y1, Y2, Y3}		{0.25, 0.4, 0.45, 0.25, 0.28, 0.4}				
Optical Return Loss Tolerance		-	-	20	dB	
Average Launch Power OFF Transmitter, each Lane	Poff			-30	dBm	
Relative Intensity Noise	Rin			-128	dB/HZ	1
Optical Return Loss Tolerance		-	-	12	dB	
Receiver						
Damage Threshold	THd	0			dBm	1
Average Power at Receiver Input, each Lane	R	-24		-6	dBm	
Receive Electrical 3 dB upper Cut off Frequency, each Lane				12.3	GHz	
RSSI Accuracy		-2		2	dB	
Receiver Reflectance	Rrx			-26	dB	
Receiver Power (OMA), each Lane		-	-	-4	dBm	

Receive Electrical 3 dB upper Cutoff Frequency, each Lane				12.3	GHz	
LOS De-Assert	LOSD			-25	dBm	
LOS Assert	LOSA	-35			dBm	
LOS Hysteresis	LOSH	0.5			dB	

Note 1: 12dB Reflection

Diagnostic Monitoring Interface

Digital diagnostics monitoring function is available on all QSFP+ ER4. A 2-wire serial interface provides user to contact with module. The structure of the memory is shown in flowing. The memory space is arranged into a lower, single page, address space of 128 bytes and multiple upper address space pages. This structure permits timely access to addresses in the lower page, such as Interrupt Flags and Monitors. Less time critical time entries, such as serial ID information and threshold settings, are available with the Page Select function. The interface address used is A0xh and is mainly used for time critical data like interrupt handling in order to enable a one-time-read for all data related to an interrupt situation. After an interrupt, IntL has been asserted, the host can read out the flag field to determine the affected channel and type of flag.

Byte Address	Description	Type
0	Identifier (1 Byte)	Read Only
1-2	Status (2 Bytes)	Read Only
3-21	Interrupt Flags (31 Bytes)	Read Only
22-33	Module Monitors (12 Bytes)	Read Only
34-81	Channel Monitors (48 Bytes)	Read Only
82-85	Reserved (4 Bytes)	Read Only
86-97	Control (12 Bytes)	Read/Write
98-99	Reserved (2 Bytes)	Read/Write
100-106	Module and Channel Masks (7 Bytes)	Read/Write
107-118	Reserved (12 Bytes)	Read/Write
119-122	Reserved (4 Bytes)	Read/Write
123-126	Reserved (4 Bytes)	Read/Write
127	Page Select Byte	Read/Write

Byte Address	Description	Type
128-175	Module Thresholds (48 Bytes)	Read Only
176-223	Reserved (48 Bytes)	Read Only
224-225	Reserved (2 Bytes)	Read Only
226-239	Reserved (14 Bytes)	Read/Write
240-241	Channel Controls (2 Bytes)	Read/Write
242-253	Reserved (12 Bytes)	Read/Write
254-255	Reserved (2 Bytes)	Read/Write

2-wire serial address, 1010000x (A0h)"

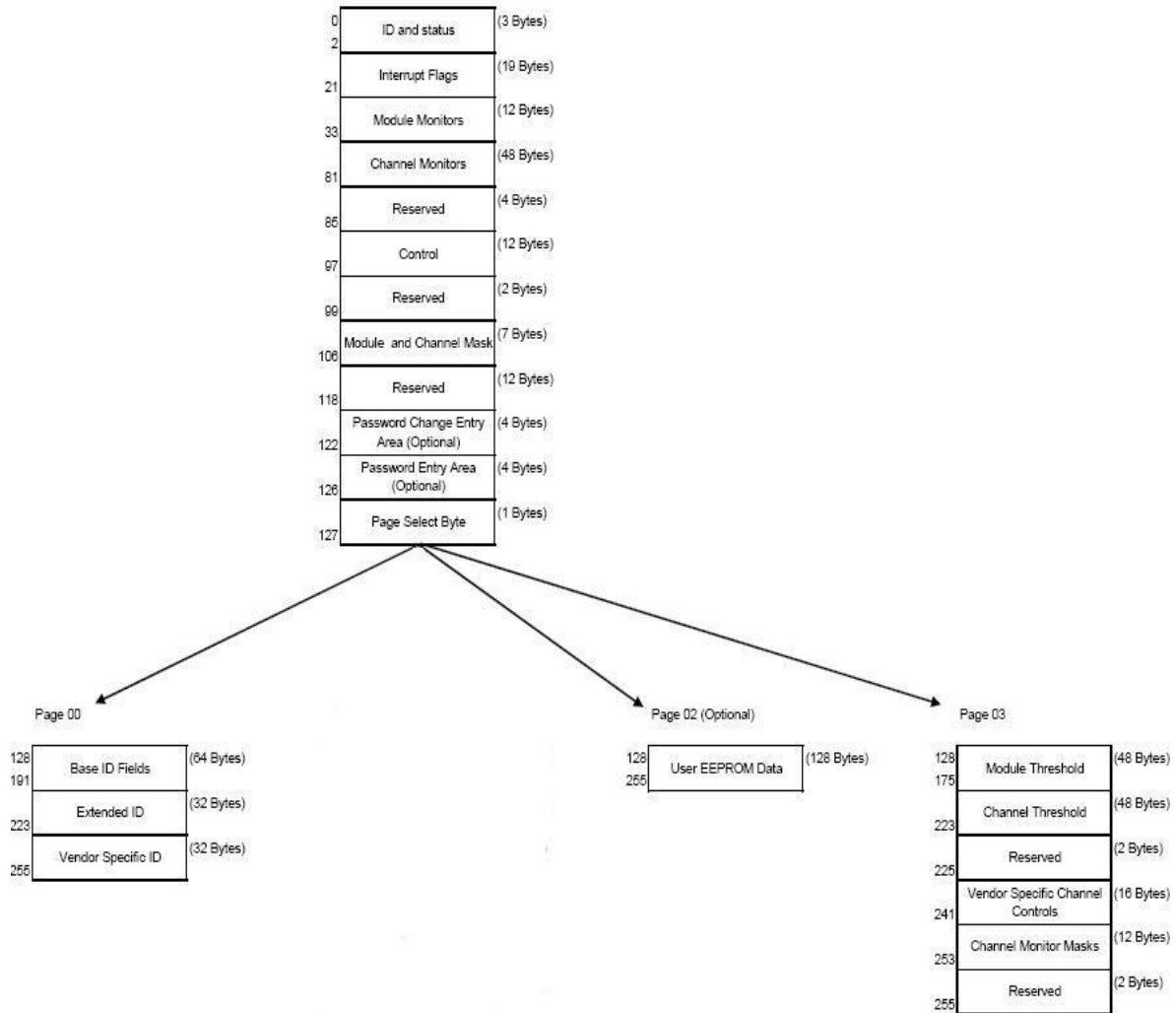

EEPROM Serial ID Memory Contents (A0h)

Data Address	Length (Byte)	Name of Length	Description and Contents
Base ID Fields			
128	1	Identifier	Identifier Type of serial Module(D=QSFP+)
129	1	Ext. Identifier	Extended Identifier of Serial Module(90=2.5W)
130	1	Connector	Code of connector type(7=LC)
131-138	8	Specification compliance	Code for electronic compatibility or optical compatibility(40GBASE-LR4)
139	1	Encoding	Code for serial encoding algorithm(5=64B66B)
140	1	BR, Nominal	Nominal bit rate, units of 100 Mbits/s(6C=108)
141	1	Extended Rate Select Compliance	Tags for extended rate select compliance
142	1	Length (SMF)	Link length supported for SMF fiber in km (28=80km)
143	1	Length(OM3 50um)	Link length supported for EBW 50/125um fiber(OM3), units of 2m
144	1	Length(OM2 50um)	Link length supported for 50/125um fiber(OM2), units of 1m
145	1	Length(OM1 62.5um)	Link length supported for 62.5/125um fiber (OM1), units of 1m
146	1	Length(Copper)	Link length of copper or active cable, unites of 1m Link length supported for 50/125um fiber (OM4), units of 2m when Byte 147 declares 850nm VCSEL as defined in Table 37
147	1	Device tech	Device technology
148-163	16	Vendor name	QSFP+ vendor name: TIBTRONIX (ASCII)
164	1	Extended Module	Extended Module codes for InfiniBand
165-167	3	Vendor OUI	QSFP+ vendor IEEE company ID(000840)
168-183	16	Vendor PN	Part number: TQPLFG80D (ASCII)
184-185	2	Vendor rev	Revision level for part number provided by vendor (ASCII) (X1)
186-187	2	Wave length or Copper cable Attenuation	Nominal laser wavelength (wavelength=value/20 in nm) or copper cable attenuation in dB at 2.5GHz (Adrs 186) and 5.0GHz (Adrs 187) (65A4=1301)

188-189	2	Wavelength tolerance	Guaranteed range of laser wavelength(+/- value) from nominal wavelength. (wavelength Tol.=value/200 in nm) (1C84=36.5)
190	1	Max case temp.	Maximum case temperature in degrees C (70)
191	1	CC_BASE	Check code for base ID fields (addresses 128-190)
Extended ID fields			
192-195	4	Options	Rate Select, TX Disable, Tx Fault, LOS, Warning indicators for: Temperature, VCC, RX, power, TX Bias
196-211	16	Vendor SN	Serial number provided by vendor (ASCII)
212-219	8	Date Code	Vendor's manufacturing date code
220	1	Diagnostic Monitoring Type	Indicates which types of diagnostic monitoring are implemented (if any) in the Module. Bit 1, 0 Reserved (8=Average Power)
221	1	Enhanced Options	Indicates which optional enhanced features are implemented in the Module.
222	1		Reserved
223	1	CC_EXT	Check code for the Extended ID Fields (addresses 192-222)
Vendor Specific ID Fields			
224-255	32		Vendor Specific EEPROM

Timing for Soft Control and Status Functions

Parameter	Symbol	Max	Unit	Conditions
Initialization Time	t_init	2000	ms	Time from power on ¹ , hot plug or rising edge of Reset until the module is fully functional ²
Reset Init Assert Time	t_reset_init	2	μs	A Reset is generated by a low level longer than the minimum reset pulse time present on the ResetL pin.
Serial Bus Hardware Ready Time	t_serial	2000	ms	Time from power on ¹ until module responds to data transmission over the 2-wire serial bus
Monitor Data Ready Time	t_data	2000	ms	Time from power on ¹ to data not ready, bit 0 of Byte 2, deasserted and IntL asserted
Reset Assert Time	t_reset	2000	ms	Time from rising edge on the ResetL pin until the module is fully functional ²

LPMode Assert Time	ton_LPMode	100	μ s	Time from assertion of LPMode (Vin:LPMode =Vih) until module power consumption enters lower Power Level
IntL Assert Time	ton_IntL	200	ms	Time from occurrence of condition triggering IntL until Vout:IntL = Vol
IntL Deassert Time	toff_IntL	500	μ s	toff_IntL 500 μ s Time from clear on read3 operation of associated flag until Vout:IntL = Voh. This includes deassert times for Rx LOS, Tx Fault and other flag bits.
Rx LOS Assert Time	ton_los	100	ms	Time from Rx LOS state to Rx LOS bit set and IntL asserted
Flag Assert Time	ton_flag	200	ms	Time from occurrence of condition triggering flag to associated flag bit set and IntL asserted
Mask Assert Time	ton_mask	100	ms	Time from mask bit set4 until associated IntL assertion is inhibited
Mask De-assert Time	toff_mask	100	ms	Time from mask bit cleared4 until associated IntL operation resumes
ModSelL Assert Time	ton_ModSelL	100	μ s	Time from assertion of ModSelL until module responds to data transmission over the 2-wire serial bus
ModSelL Deassert Time	toff_ModSelL	100	μ s	Time from deassertion of ModSelL until the module does not respond to data transmission over the 2-wire serial bus
Power_over-ride or Power-set Assert Time	ton_Pdown	100	ms	Time from P_Down bit set 4 until module power consumption enters lower Power Level
Power_over-ride or Power-set De-assert Time	toff_Pdown	300	ms	Time from P_Down bit cleared4 until the module is fully functional3

Note:

1. Power on is defined as the instant when supply voltages reach and remain at or above the minimum specified value.
2. Fully functional is defined as IntL asserted due to data not ready bit, bit 0 byte 2 de-asserted.
3. Measured from falling clock edge after stop bit of read transaction.
4. Measured from falling clock edge after stop bit of write transaction.

Pin Assignment

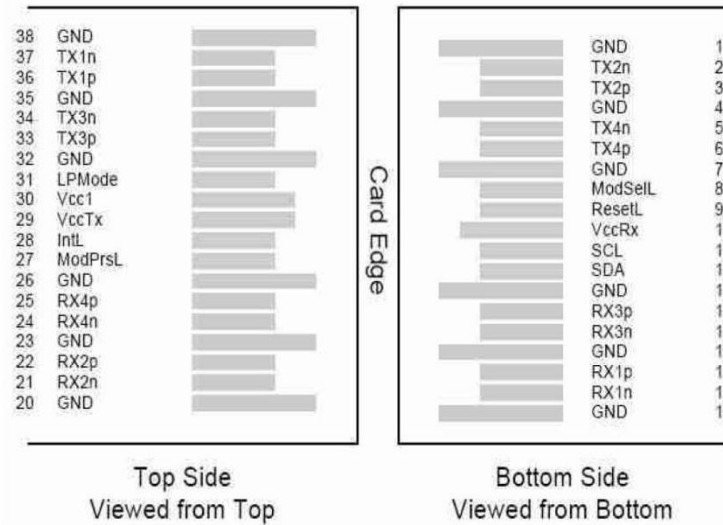

Diagram of Host Board Connector Block Pin Numbers and Name

Pin Description

Pin	Logic	Symbol	Name/Description	Notes
1		GND	Ground	1
2	CML-I	Tx2n	Transmitter Inverted Data Input	
3	CML-I	Tx2p	Transmitter Non-Inverted Data output	
4		GND	Ground	1
5	CML-I	Tx4n	Transmitter Inverted Data Output	
6	CML-I	Tx4p	Transmitter Non-Inverted Data Output	
7		GND	Ground	1
8	LVTTL-I	ModSelL	Module Select	
9	LVTTL-I	ResetL	Module Reset	
10		VccRx	+3.3V Power Supply Receiver	2
11	LVC MOS-I/O	SCL	2-Wire Serial Interface Clock	
12	LVC MOS-I/O	SDA	2-Wire Serial Interface Data	
13		GND	Ground	1

14	CML-O	Rx3p	Receiver Inverted Data Output	
15	CML-O	Rx3n	Receiver Non-Inverted Data Output	
16		GND	Ground	1
17	CML-O	Rx1p	Receiver Inverted Data Output	
18	CML-O	Rx1n	Receiver Non-Inverted Data Output	
19		GND	Ground	1
20		GND	Ground	1
21	CML-O	Rx2n	Receiver Inverted Data Output	
22	CML-O	Rx2p	Receiver Non-Inverted Data Output	
23		GND	Ground	1
24	CML-O	Rx4n	Receiver Inverted Data Output	
25	CML-O	Rx4p	Receiver Non-Inverted Data Output	
26		GND	Ground	1
27	LVTTL-O	ModPrsL	Module Present	
28	LVTTL-O	IntL	Interrupt	
29		VccTx	+3.3V Power Supply Transmitter	2
30		Vcc1	+3.3V Power Supply	2
31	LVTTL-I	LPMODE	Low Power Mode	
32		GND	Ground	1
33	CML-I	Tx3p	Transmitter Inverted Data Output	
34	CML-I	Tx3n	Transmitter Non-Inverted Data Output	
35		GND	Ground	1
36	CML-I	Tx1p	Transmitter Inverted Data Output	
37	CML-I	Tx1n	Transmitter Non-Inverted Data Output	
38		GND	Ground	1

Notes

1. GND is the symbol for single and supply(power) common for QSFP modules, All are

common within the QSFP module and all module voltages are referenced to this potential otherwise noted. Connect these directly to the host board signal common ground plane. Laser output disabled on TDIS >2.0V or open, enabled on TDIS <0.8V.

2. VccRx, Vcc1 and VccTx are the receiver and transmitter power suppliers and shall be applied concurrently. Recommended host board power supply filtering is shown below. VccRx, Vcc1 and VccTx may be internally connected within the QSFP transceiver module in any combination. The connector pins are each rated for maximum current of 500mA.

Recommended Circuit

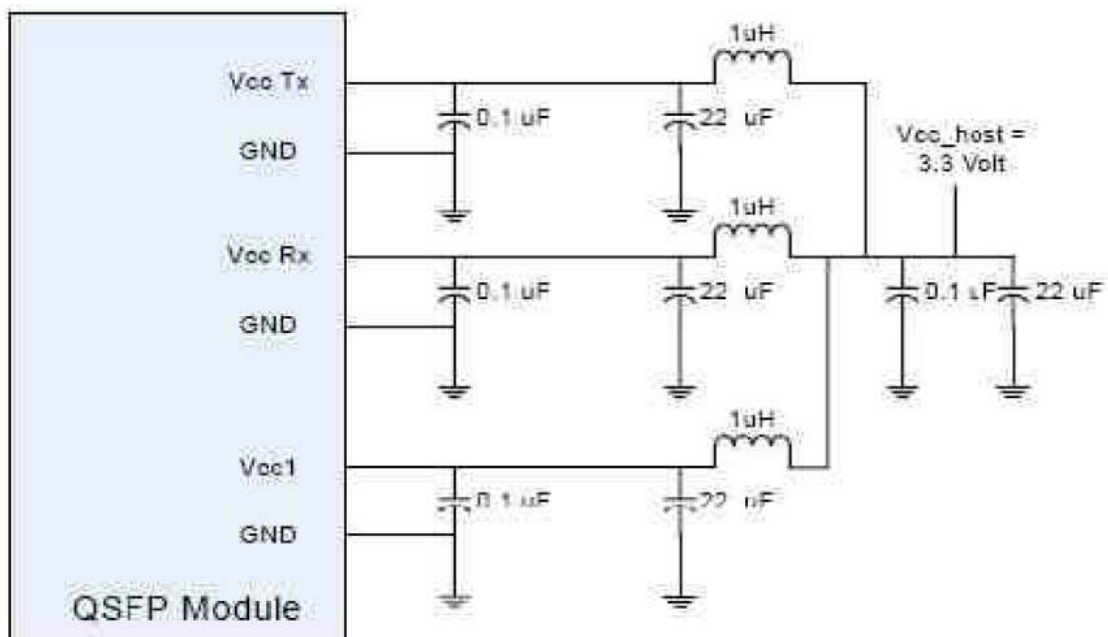

Mechanical Dimensions

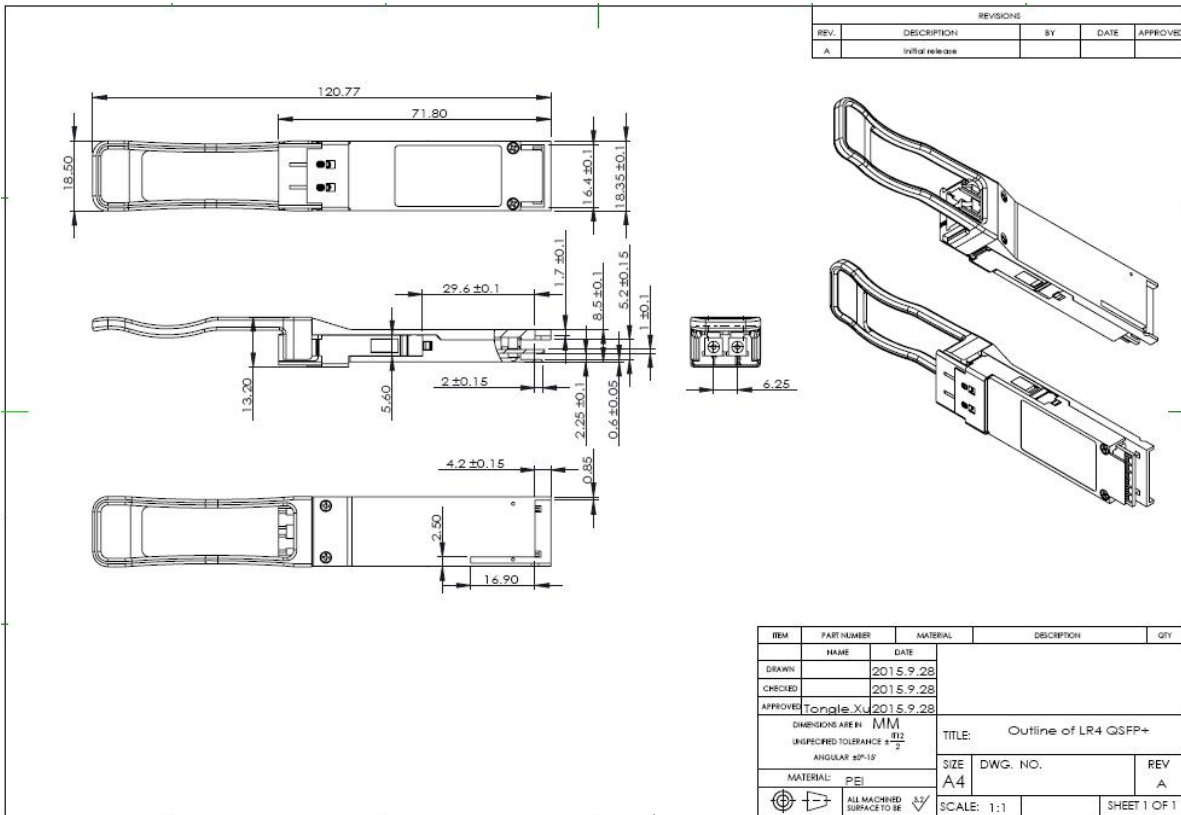

Ordering Information

Part Number	Product Description
QSFP-40G-ZR4	LAN-WDM Wavelengths, 40Gbps, LC Connectors, 80km, 0°C~+70°C, with DDM