

SFP28-25G-PCxM

25Gbps SFP28 to SFP28 Direct Attach Cables

1M, 1.5M, 2M, 2.5M, 3M, 5M Reach



Product Features

- ❖ Up to 25.78125 Gbps data rate
- ❖ Up to 5 meters transmission
- ❖ Hot-pluggable SFP 20PIN footprint
- ❖ Improved Pluggable Form Factor(IPF) compliant for enhanced EMI/EMC performance
- ❖ Compatible to SFP28 MSA
- ❖ Compatible to SFF-8402 and SFF-8432
- ❖ Temperature Range: 0~ 70 °C
- ❖ RoHS Compatible

Applications

- ❖ 25G Ethernet

Description

The SFP28 passive cable assemblies are high performance, cost effective I/O solutions for 25G Ethernet. SFP28 copper cables allow hardware manufactures to achieve high port density, configurability and utilization at a very low cost and reduced power budget.

Pin Descriptions

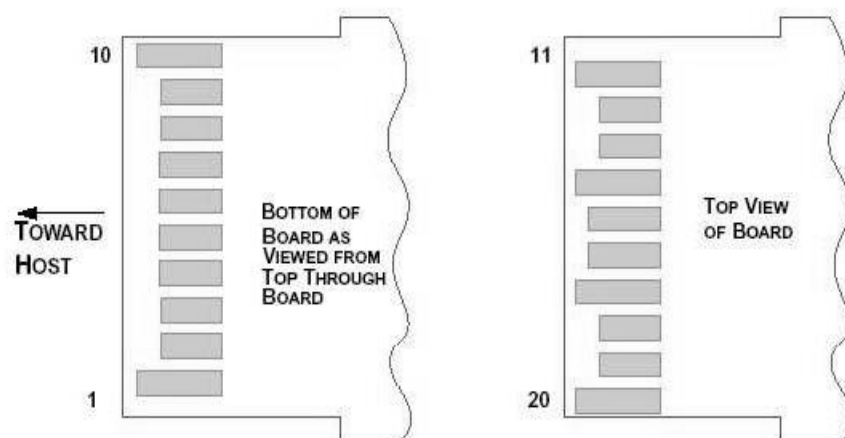

Pin	Logic	Symbol	Name/Description	Notes
1		VeeT	Transmitter Ground	
2	LV-TTL-O	TX_Fault	N/A	1
3	LV-TTL-I	TX_DIS	Transmitter Disable	2
4	LV-TTL-I/O	SDA	Tow Wire Serial Data	
5	LV-TTL-I	SCL	Tow Wire Serial Clock	
6		MOD_DEF0	Module present, connect to VeeT	
7	LV-TTL-I	RS0	N/A	1
8	LV-TTL-O	LOS	LOS of Signal	2
9	LV-TTL-I	RS1	N/A	1
10		VeeR	Reciever Ground	
11		VeeR	Reciever Ground	
12	CML-O	RD-	Reciever Data Inverted	
13	CML-O	RD+	Reciever Data Non-Inverted	
14		VeeR	Reciever Ground	
15		VccR	Reciever Supply 3.3V	
16		VccT	Transmitter Supply 3.3V	
17		VeeT	Transmitter Ground	
18	CML-I	TD+	Transmitter Data Non-Inverted	
19	CML_I	TD-	Transmitter Data Inverted	
20		VeeT	Transmitter Ground	

Note:

1. Signals not supported in SFP+ Copper pulled-down to VeeT with 30K ohms resistor
2. Passive cable assemblies do not support LOS and TX_DIS

Mechanical Dimensions

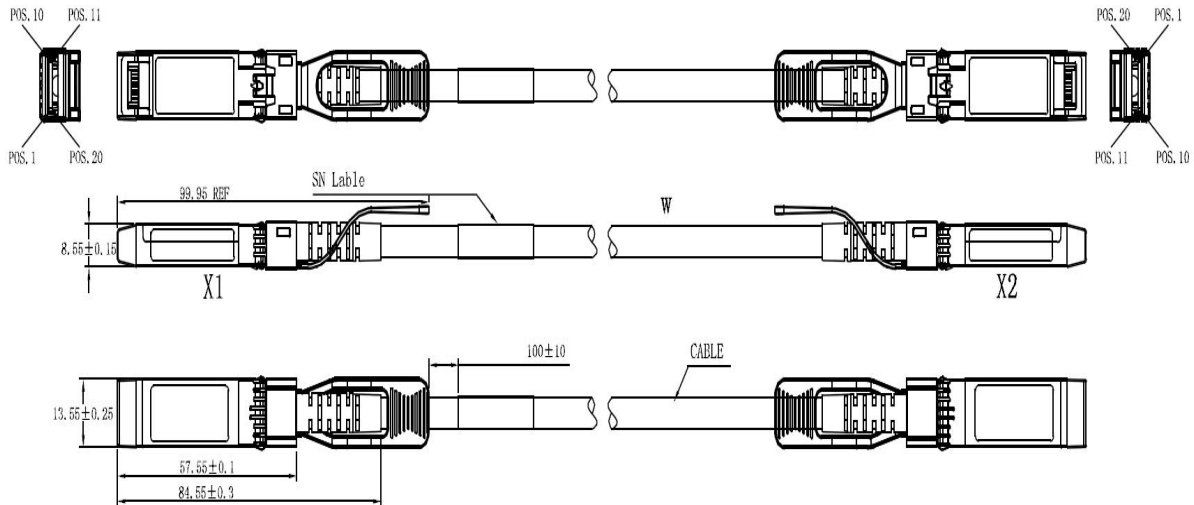

Ordering Information

Part Number	Product Description
SFP28-25G-PC1M	25G SFP28 Direct Attach Cables, 1m (3ft), AWG 30, 0 ~ 70° C
SFP28-25G-PC1.5M	25G SFP28 Direct Attach Cables, 1.5m (5ft), AWG 30, 0 ~ 70° C
SFP28-25G-PC2M	25G SFP28 Direct Attach Cables, 2m (7ft), AWG 30, 0 ~ 70° C
SFP28-25G-PC2.5M	25G SFP28 Direct Attach Cables, 2.5m (8ft), AWG 26, 0 ~ 70° C
SFP28-25G-PC3M	25G SFP28 Direct Attach Cables, 3m (10ft), AWG 26, 0 ~ 70° C
SFP28-25G-PC5M	25G SFP28 Direct Attach Cables, 5m (16ft), AWG 26, 0 ~ 70° C