

XGPON1-OLT-XN2a

T9.95Gbps/R2.5Gbps N2a XFP XGPON OLT Transceiver

T1577nm/R1270nm



Product Features

- ❖ Single fiber bi-directional data links TX 9.953Gbps/ Burst Mode RX 2.488Gbps application
- ❖ 0 to 70°C operating case temperature
- ❖ 3.3V, 5V power supply
- ❖ XFP package with SC/UPC Receptacle connector
- ❖ Hot-pluggable capability
- ❖ High power 1577nm EML DFB LD

- ❖ High sensitivity 1270nm APD
- ❖ Support 20km transmission distance with SMF
- ❖ Low EMI and excellent ESD protection
- ❖ Digital diagnostic monitor interface

Applications

- ❖ XGPON1 OLT (ODN:N2a Class)

Standards

- ❖ Complies with INF-8077i
- ❖ Complies with ITU-T G.987.2
- ❖ Complies with FCC 47 CFR Part 15, Class B
- ❖ Complies with FDA 21 CFR 1040.10 and 1040.11

Absolute Maximum Ratings

Parameter	Symbol	Min	Max	Unit	Notes
Storage Ambient Temperature	T _{STG}	-40	85	°C	
Operating Case Temperature	T _C	0	70	°C	
Operating Humidity	OH	5	90	%	
VCC3 Power Supply Voltage	VCC	0	3.6	V	
VCC5 Power Supply Voltage	VCC	0	5.5	V	

Recommended Operating Conditions

Parameter	Symbol	Min	Typical	Max	Unit
Operating Case Temperature	T _c	0		+70	°C
VCC3 Power Supply Voltage	V _{CC}	3.13	3.3	3.47	V
VCC5 Power Supply Voltage	V _{CC}	4.75	5	5.25	V
VCC3 Power Supply Current	ICC		-	1000	mA
VCC5 Power Supply Current	ICC		-	500	mA
Date Rate			9.953/2.488		Gbps
Date Rate Drift		-100		+100	PPM

Transmitter Optical Characteristics

Parameter	Symbol	Min	Typical	Max	Unit	Notes
Optical Center Wavelength	λ_C	1575		1580	nm	
Optical Spectrum Width (-20dB)	$\Delta\lambda$	-	-	1	nm	
Side Mode Suppression Ratio	SMSR	30			dB	
Average Launch Optical Power	AOP	+4		+8	dBm	Launched into SMF
Power-OFF Transmitter Optical Power				-39	dBm	Launched into SMF
Extinction Ratio	ER	8.2			dB	PRBS ²³¹ -1 @9.953Gbps
Transmitter Reflectance				-10	dB	
Transmitter Tolerance to Reflected Optical Power		-15			dB	
Transmitter and Dispersion Penalty	TDP			1	dB	Transmit on 20km SMF
Optical Waveform Diagram	Compliant with ITU-T 987.2					Mask Margin>5%

Transmitter Electrical Characteristics

Parameter	Symbol	Min	Typical	Max	Unit	Notes
Data Input Differential Swing		120		820	mV	CML input, AC coupled
Input Differential Impedance		90	100	110	Ω	
Transmitter Disable Voltage - Low		0		0.8	V	Transmitter On
Transmitter Disable Voltage - High		2.0		V _{CC}	V	Transmitter Off
Transmitter Fault Voltage - Low		0		0.4	V	Transmitter On
Transmitter Fault Voltage - High		2.4		V _{CC}	V	Transmitter Fault

Transmitter Eye Mask Definitions and Test Procedure

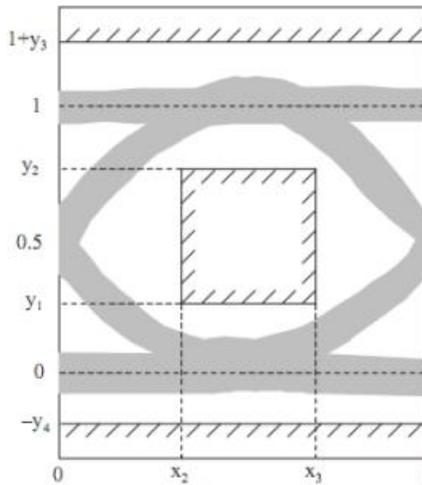

Figure 1: XGPON Transmitter Eye Mask Definitions

X3-X2	Y1	Y2	Y3	Y4	Unit
0.2	0.25	0.75	0.25	0.25	UI

Receiver Optical Characteristics

Parameter	Symbol	Min	Typical	Max	Unit	Notes
Operating Wavelength		1260		1280	nm	
Sensitivity	SEN			-29.5	dBm	PRBS 2 ²³ -1 @2.488Gbps BER ≤1×10 ⁻⁴
Saturation Optical Power	SAT	-9			dBm	PRBS 2 ²³ -1 @2.488Gbps BER ≤1×10 ⁻⁴
Burst Dynamic Range		15			dB	
Signal Detect Assert Level				-30	dBm	
Signal Detect De-assert Level		-45			dBm	
Loss Of Signal Hysteresis		0.5		6	dB	
Receiver Reflectance				-20	dB	

Receiver Electrical Characteristics

Parameter	Symbol	Min	Typical	Max	Unit	Notes
Receiver Amplitude Recovery Time	Trec			64	bit	Figure 2
Data Output Differential Swing		400		1200	mV	CML output, DC coupled
Reset Width	Trw	32			bits	
Reset-Low		0		0.8	V	
Reset-High		2.0		Vcc	V	
Signal Detect Assert Time	Tsda			100	ns	
Signal Detect De-assert Time	Tsdd			12.8	ns	Refer to the Reset signal rising edge
Signal Detect Voltage-Low		0		0.4	V	
Signal Detect Voltage-High		2.4		Vcc	V	
RSSI Trigger-Low		0		0.8	V	
RSSI Trigger-High		2.0		Vcc	V	
RSSI Trigger Delay	T _D	0		100	ns	Figure 4

RSSI Trigger Width	T_w	350		350	ns	Figure 4
I ² C Access Prohibited Time	T_P	500		500	μ s	Figure 4

Timing Parameter Definitions in Burst Mode Sequence

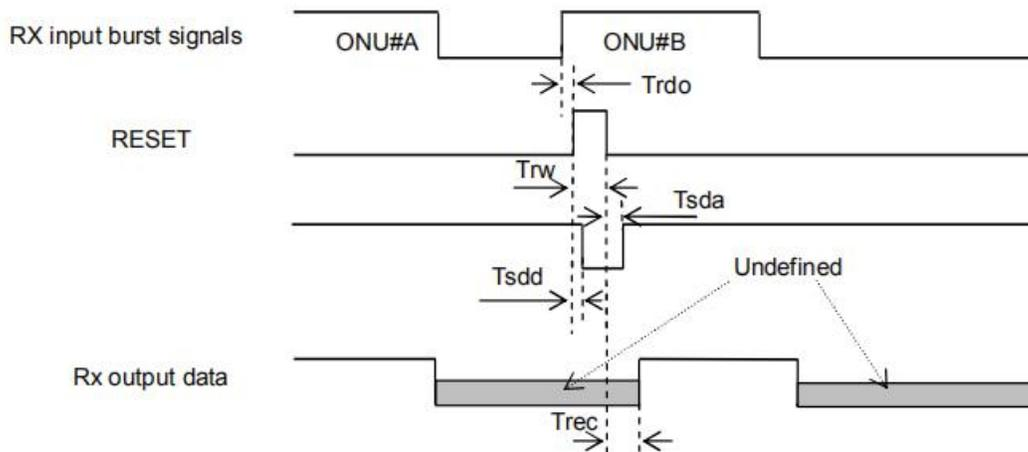

Figure 2: Timing Parameter Definitions in Burst Mode Sequence

Burst Mode Receiver Dynamic Range

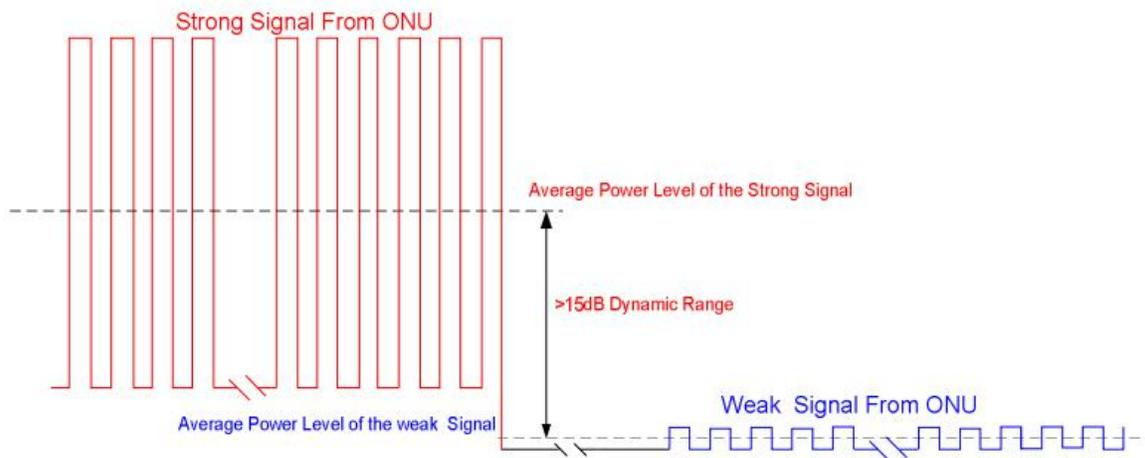

Figure 3: Burst Mode Receiver Dynamic Range in XGPON System

Timing Parameter Definitions in RSSI Trigger

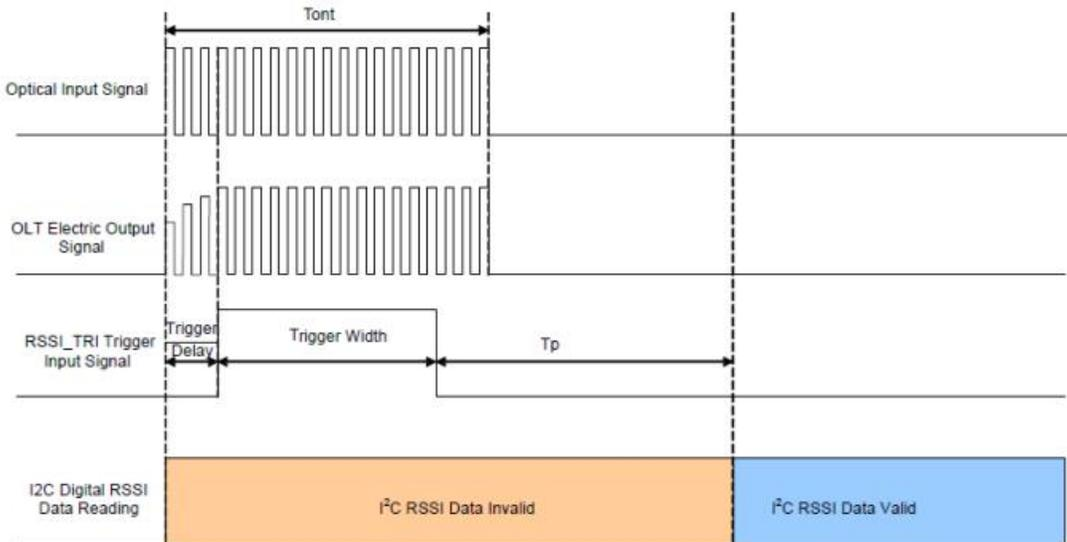

Figure 4 Timing Parameter Definitions in RSSI Trigger

Pin Description

PIN	Name	Description	Notes
1	GND	Module Ground	
2	TX Fault	Transmitter Fault Indication	LVTTL, High Indicates TX Laser Fault
3	N.C.	Not be Connected in the transceiver	
4	N.C.	Not be Connected in the transceiver	
5	TX_DIS	Transmitter Disable	LVTTL, Low: transmitter on
6	VCC5	+5V Power Supply	
7	GND	Module Ground	
8	VCC3_TX	Transmitter 3.3V Power Supply	
9	VCC3_RX	Receiver 3.3V Power Supply	
10	SCL	The clock line	The clock line of two wire serial interface
11	SDA	The data line	The data line of two wire serial interface

12	MOD_ABS	Indicates Module is not present	LVTTTL, this pin shall be pulled-up by Host and grounded in the module.
13	RX_Reset	Burst Receiver Reset	LVTTTL, High level Reset
14	RX_SD	Receiver signal detected indication	LVTTTL, high level indicates burst packet is detected
15	GND	Module Ground	
16	GND	Module Ground	
17	RD-	Inverted Received Data Out	CML Output, DC coupled, Squelched by LOS
18	RD+	Non-inverted Received Data Out	CML Output, DC coupled, Squelched by LOS
19	GND	Module Ground	
20	N.C.	Not be Connected in the transceiver	
21	RSSI_TRIG	RSSI trigger for Transceiver A/D converter	LVTTTL, High active
22	NC	Not be Connected in the transceiver	
23	GND	Module Ground	
24	N.C.	Not be Connected in the transceiver	
25	N.C	Not be Connected in the transceiver	
26	GND	Module Ground	
27	GND	Module Ground	
28	TX-	Inverted Transmit Data in	CML input, AC coupled
29	TX+	Non-Inverted Transmit Data in	CML input, AC coupled
30	GND	Module Ground	

Pin Out Drawing

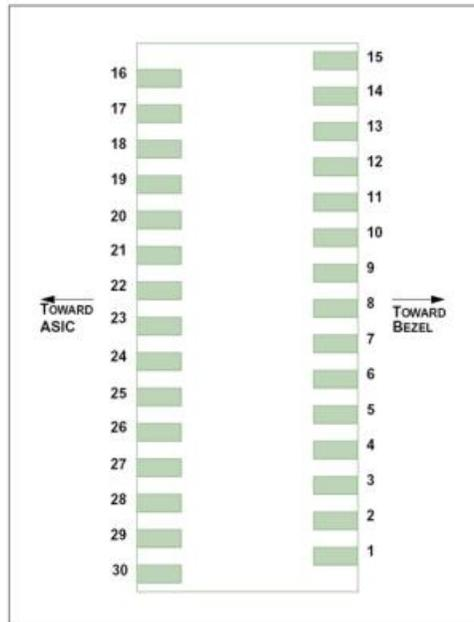
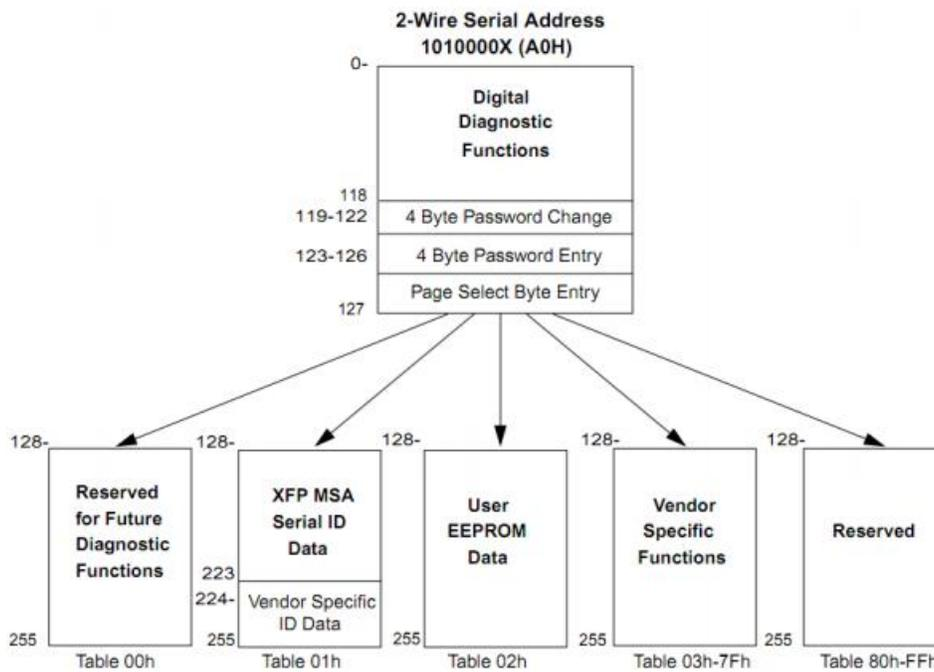

Figure 5: Pin Out Drawing

EEPROM Memory Map Specific Data Field Description



Typical Interface Circuit

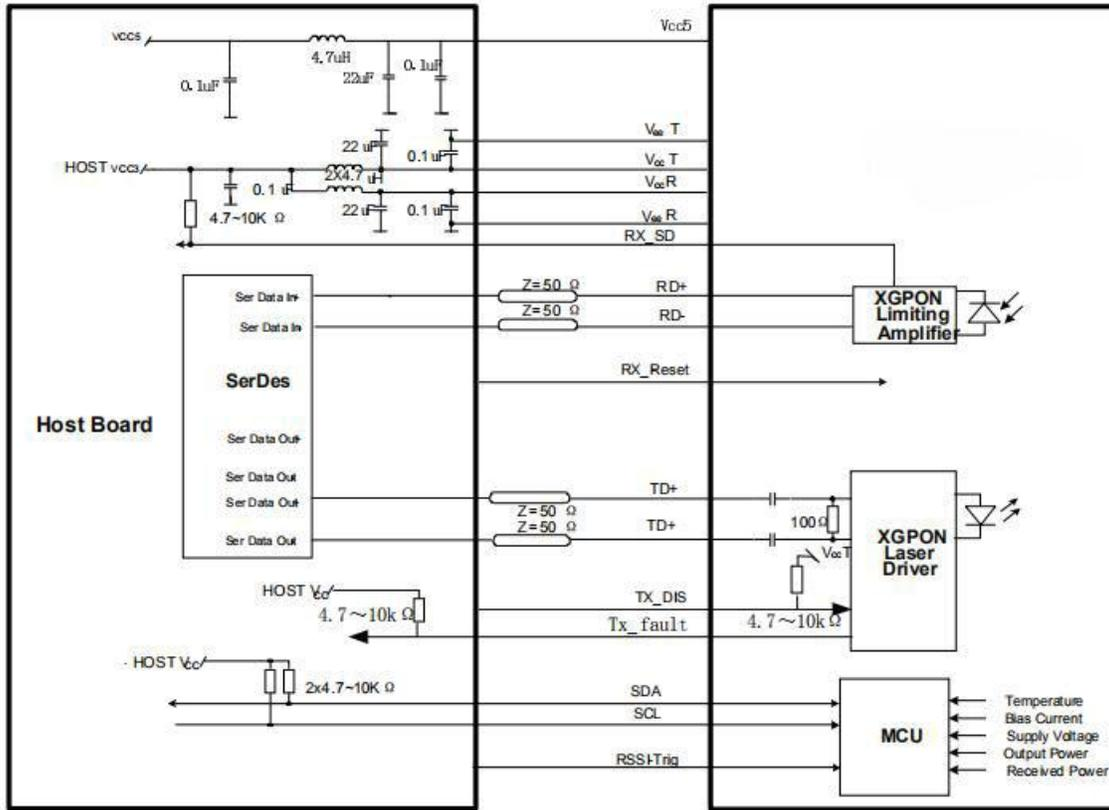
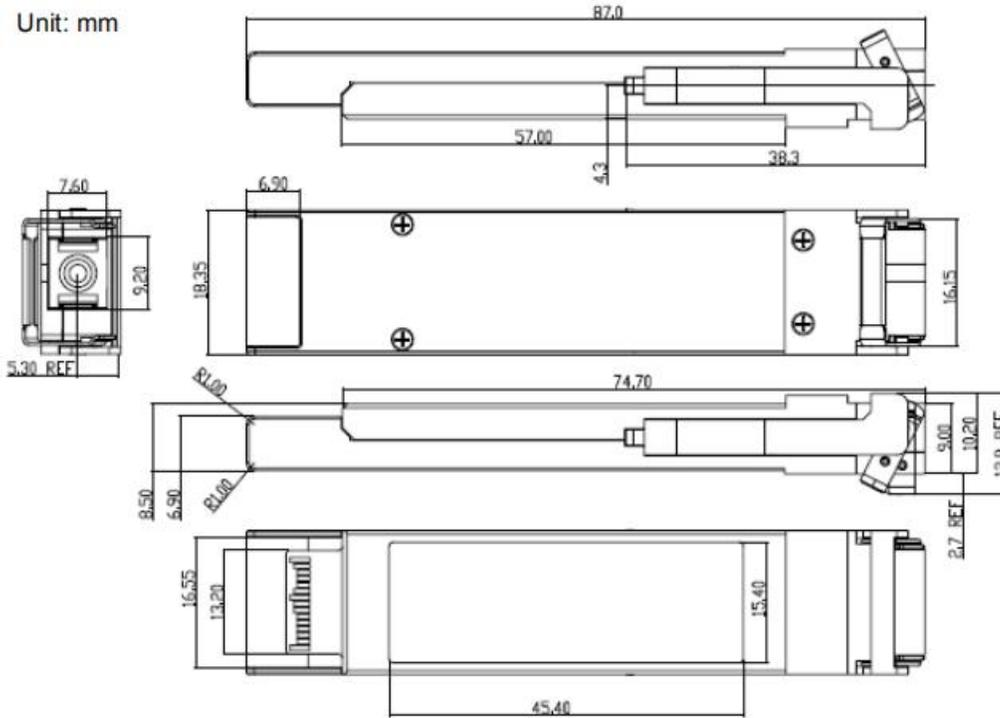

Figure 6: Typical Interface Circuit

Digital Diagnostic Monitoring Interface

Parameter	Range	Accuracy	Calibration	Notes
Temperature	-5 to 75° C	±3°C	Internal	1LSB = 1/256° C
Voltage	3.0 to 3.6 V	±3%	Internal	1LSB = 0.1mV
Bias Current	0 to 131mA	±10%	Internal	1LSB = 2uA
TX Power	0 to 8dBm	±3dB	Internal	1LSB = 0.1uW
RX Power Monitor	-30 to -7dBm	±3dB	Internal	1LSB = 0.1uW

Package Outline



Ordering Information

Part Number	XGPON1-OLT-XN2a
Application	XG-PON1 OLT, 0°C~+70°C
Wavelength (nm)	1577T/1270R
Data Rate (Gb/s)	9.95T/2.5R
ODN Class	N2a
Package	XFP
Connector	SC